

Petro Industry Energy Co.

Products Manufactured by PIE Include :

- Forged Steel Gate Valves
- Forged Steel Globe Valves
- Forged Steel Check Valves
- Ball Valves
- Butterfly Valves

HEAD OFFICE

Unit 14 , No 9, Azadegan
Alley, Ghaem Magham
Farahani Ave, Tehran , Iran

Tel: +98 88704966, 88704960
Fax: +98 88726555
Website: <http://www.pie.ir>
Email: Pie@Pie.ir

FACTORY

No 3414, Sabalan St2, Eastern
Hesabi blvd, Industrial town,
Eshtehard, Iran

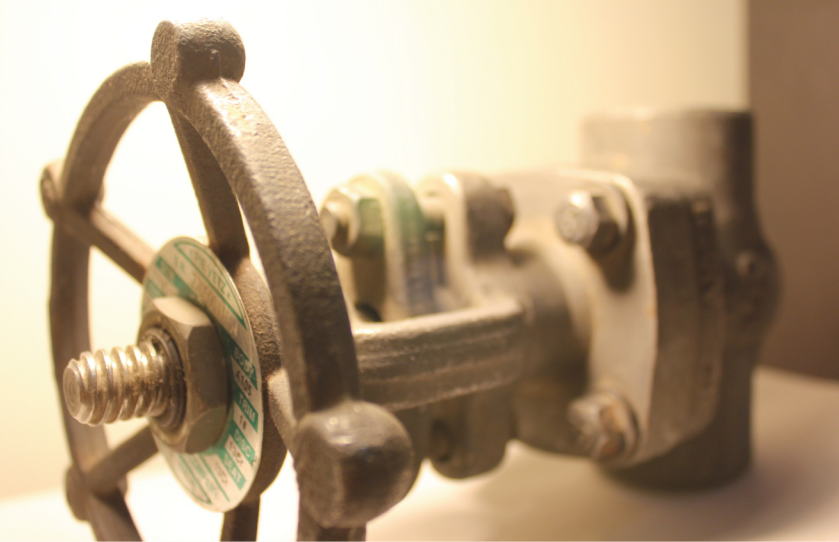

Forged Steel Valves

You Can Trust, We Can DO It

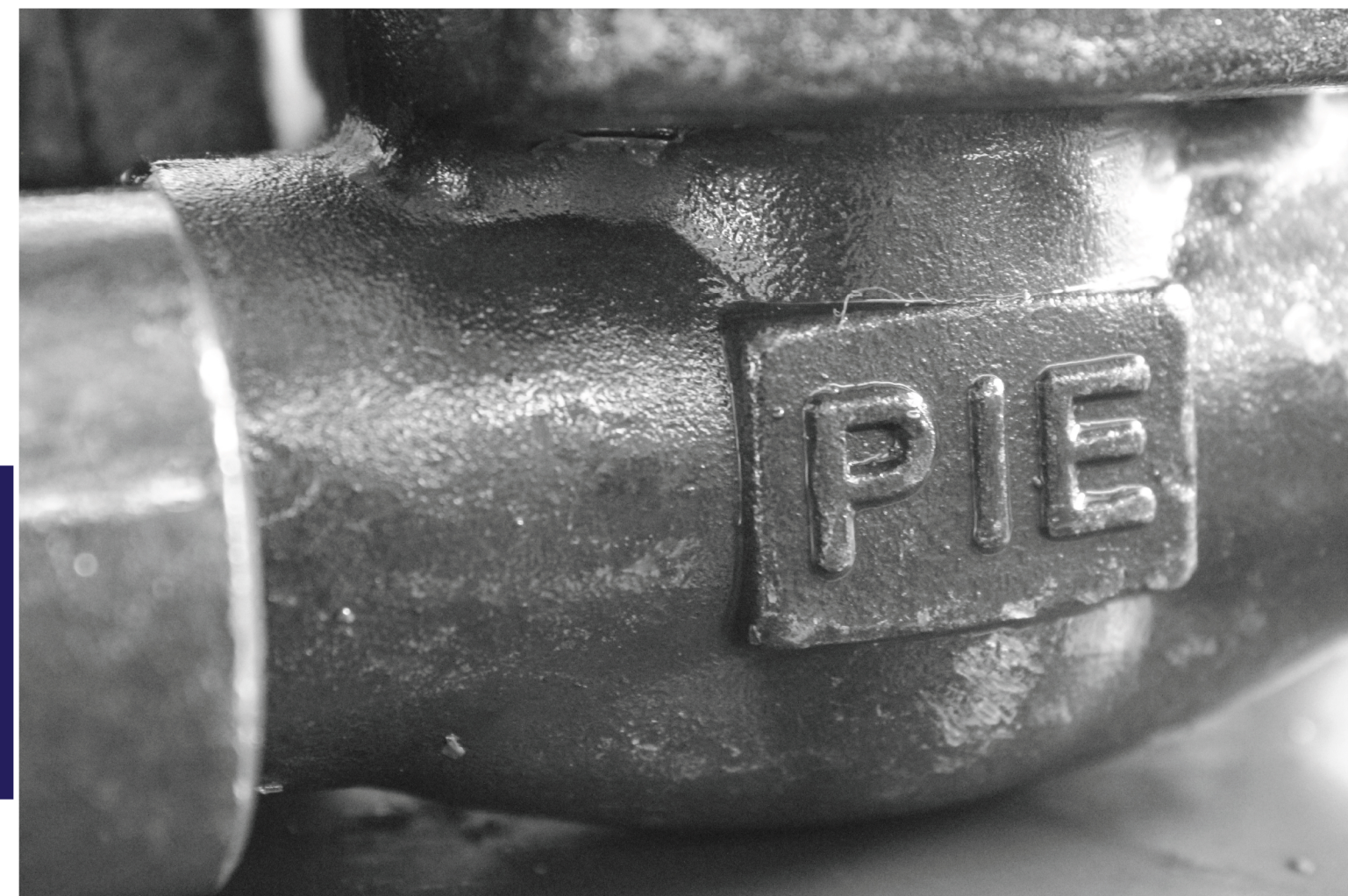

● Foreword

Petro energy industry since 1383 its activities with the import of valves and fittings and pipes used in oil, gas, petrochemical and power industries began and the dominance of corporate objectives in a way that is independent Islamic homeland in 1385, the It was a step, however small, to promote the self-sufficiency and to embrace factory to produce all kinds of valves FORGED STEEL and CAST STEEL PIE brand and the tumultuous body in this way.

The products are based on global standards API, ASTM, BSI and other approved standards of the oil industry in the world is produced, the company since 1386 as a member of the Association of Iranian Petroleum Industries Equipment Manufacturers Tabtvand accordingly benefit from the experiences of the leaders in the industry.

Petro energy industry in order to expand its imports in 1389 to set up offices abroad to provide all kinds of pipes, fittings and valves is out of range of its products to meet more and more employers are.

The company is equipped with hydraulic and hydrostatic testing and repair of various types of valves are equipped with the necessary safety testing and certification of non-valid test our products are exported to product testing, be sure to noted for certification, the company in collaboration with the secret Metallurgical certificates including materials testing, mechanical and Non-Destructive Testing and exports. the Directory.

- GLOBE



Contents

Introduction

Specification

Gate Valve	3-10
Globe Valve	11-21
Check Valve	22-32

Pressure-Temperature Rating

33-37

Standard Material Specification

38-40

CV Values

41

How to Order

42



**Critical Service
Valves for the
World's Industries**

GATE VALVES – BOLTED / WELDED BONNET – REDUCED / FULL PORT

GATE VALVES – BOLTED / WELDED BONNET – REDUCED PORT

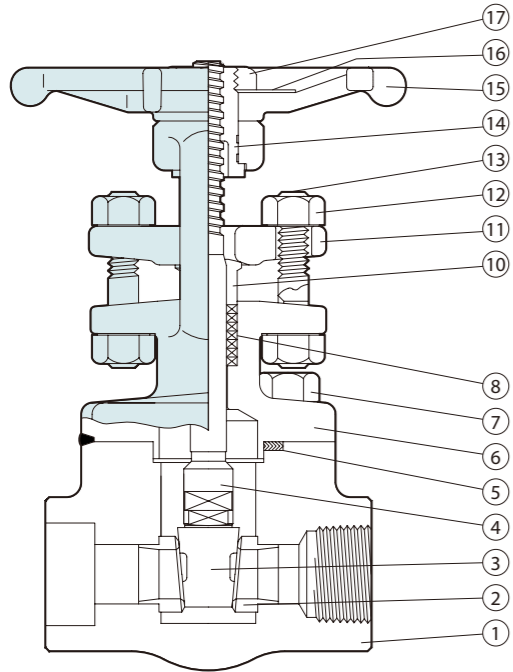

No.	Parts	Material	A.S.T.M.
1	Body	Forged Steel	A105N
2	Seat Ring	Stellite 6 faced A276-410	
3	Wedge	13Cr Stainless Steel	A217-CA15
4	Stem	13Cr Stainless Steel	A276-410
5	Gasket	304 Spiral Wound Graphite	
6	Bonnet	Forged Steel	A105N
7	Bonnet Bolt	Alloy Steel	A193-B7
8	Gland Packing	Graphoil	
10	Gland	Stainless Steel	A276-316
11	Gland Flange	Forged Steel	A105
12	Gland Nut	Carbon Steel	A194-2H
13	Gland Bolt	Stainless Steel	A193-B6
14	Yoke Sleeve	13Cr Stainless Steel	A582-416
15	Handwheel	Malleable Iron	A47
16	Name Plate	Aluminum	
17	Handwheel Nut	Carbon Steel	A563A

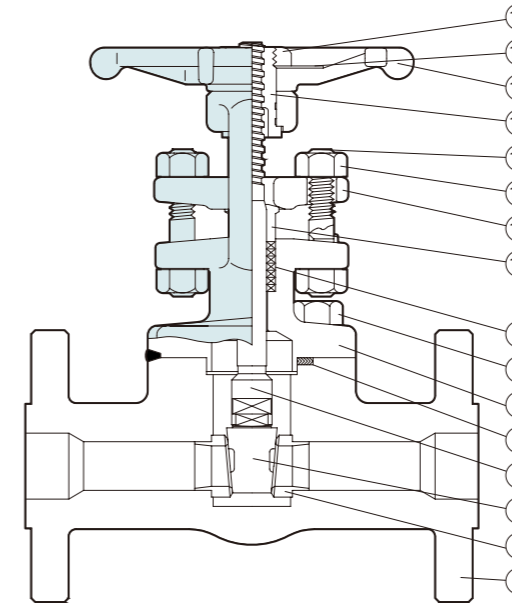

No.	Parts	Material	A.S.T.M.
1	Body	Forged Steel	A105N
2	Seat Ring	Stellite 6 faced A276-410	
3	Wedge	13Cr Stainless Steel	A217-CA15
4	Stem	13Cr Stainless Steel	A276-410
5	Gasket	304 Spiral Wound Graphite	
6	Bonnet	Forged Steel	A105N
7	Bonnet Bolt	Alloy Steel	A193-B7
8	Gland Packing	Graphoil	
10	Gland	Stainless Steel	A276-316
11	Gland Flange	Forged Steel	A105
12	Gland Nut	Carbon Steel	A194-2H
13	Gland Bolt	Stainless Steel	A193-B6
14	Yoke Sleeve	13Cr Stainless Steel	A582-416
15	Handwheel	Malleable Iron	A47
16	Name Plate	Aluminum	
17	Handwheel Nut	Carbon Steel	A563A

CLASS 600 / 800 - API 602 / ASME B16.34

Unit: mm (inch)

Port	Valve Size	Handwheel Diameter	End to End	Center to Top (Open)	Dia. of Port Openings	Weight Kg (Lb)
Reduced	1/2	86 (3.39)	76 (2.99)	145 (5.71)	9.8 (0.39)	1.5 (3.3)
	3/4	86 (3.39)	86 (3.39)	151 (5.95)	13.0 (0.51)	2.0 (4.4)
	1	99 (3.90)	102 (4.02)	190 (7.48)	18.0 (0.71)	2.8 (6.2)
	1 1/4	124 (4.88)	117 (4.61)	241 (9.49)	31.0 (1.22)	5.2 (11.5)
	1 1/2	124 (4.88)	117 (4.61)	241 (9.49)	31.0 (1.22)	5.2 (11.5)
2	138 (5.43)	133 (5.24)	271 (10.67)	37.0 (1.46)	8.2 (18.8)	
Full	1/2	86 (3.39)	86 (3.39)	151 (5.95)	13.0 (0.51)	2.0 (4.4)
	3/4	99 (3.90)	102 (4.02)	190 (7.48)	18.0 (0.71)	2.8 (6.2)
	1	124 (4.88)	117 (4.61)	241 (9.49)	23.0 (0.91)	5.2 (11.5)
	1 1/4	138 (5.43)	133 (5.24)	271 (10.67)	37.0 (1.46)	8.2 (18.8)
	1 1/2	138 (5.43)	133 (5.24)	271 (10.67)	37.0 (1.46)	8.2 (18.8)
2	157 (6.18)	218 (8.58)	318 (12.52)	50.8 (2.00)	12.7 (28.0)	

CLASS 1500 - API 602 / ASME B16.34

Unit: mm (inch)

Port	Valve Size	Handwheel Diameter	End to End	Center to Top (Open)	Dia. of Port Openings	Weight Kg (Lb)
Reduced	1/2	86 (3.39)	86 (3.39)	151 (5.95)	9.8 (0.39)	2.0 (4.4)
	3/4	99 (3.90)	102 (4.02)	190 (7.48)	13.0 (0.51)	3.4 (7.5)
	1	124 (4.88)	117 (4.61)	241 (9.49)	18.0 (0.71)	5.8 (12.8)
	1 1/4	138 (5.43)	133 (5.24)	271 (10.67)	31.0 (1.22)	8.5 (18.7)
	1 1/2	138 (5.43)	133 (5.24)	271 (10.67)	31.0 (1.22)	8.5 (18.7)
	2	157 (6.18)	210 (8.27)	325 (12.80)	37.0 (1.46)	11.7 (25.8)

CLASS 150 / 300 / 600 - API 602 / ASME B16.34

Unit: mm (inch)

Port	Valve Size	Handwheel Diameter	Face to Face			Center to Top (Open)	Dia. of Port Openings	Weight Kg (Lb)		
			Class 150	Class 300	Class 600			Class 150	Class 300	Class 600
Reduced	1/2	86 (3.39)	108 (4.25)	140 (5.50)	165 (6.50)	145 (5.71)	9.8 (0.39)	2.5 (5.5)	3.0 (6.6)	3.3 (7.3)
	3/4	86 (3.39)	117 (4.62)	152 (6.00)	190 (7.50)	151 (5.95)	13.0 (0.51)	3.1 (6.8)	4.0 (8.8)	4.6 (10.1)
	1	99 (3.90)	127 (5.00)	165 (6.50)	216 (8.50)	190 (7.48)	18.0 (0.71)	4.7 (10.4)	6.0 (13.2)	6.6 (14.6)
	1 1/2	124 (4.88)	165 (6.50)	190 (7.50)	241 (9.50)	241 (9.49)	31.0 (1.22)	8.7 (19.2)	11.0 (24.3)	12.2 (26.9)
	2	138 (5.43)	178 (7.00)	216 (8.50)	292 (11.50)	271 (10.67)	37.0 (1.46)	12.2 (26.9)	14.0 (30.9)	15.8 (34.8)

CLASS 1500 - API 602 / ASME B16.34

Unit: mm (inch)

Port	Valve Size	Handwheel Diameter	Face to Face	Center to Top (Open)	Dia. of Port Openings	Weight Kg (Lb)
Reduced	1/2	86 (3.39)	216 (8.50)	153 (6.02)	9.8 (0.39)	6.5 (14.3)
	3/4	99 (3.90)	229 (9.00)	190 (7.58)	13.0 (0.51)	9.0 (19.9)
	1	124 (4.88)	254 (10.00)	230 (9.06)	18.0 (0.71)	13.8 (30.4)
	1 1/2	138 (5.43)	305 (12.00)	272 (10.71)	31.0 (1.22)	22.2 (49.0)
	2	157 (6.18)	368 (14.25)	325 (12.80)	37.0 (1.46)	33.2 (73.2)

GATE VALVES – BOLTED / WELDED BONNET – FULL PORT

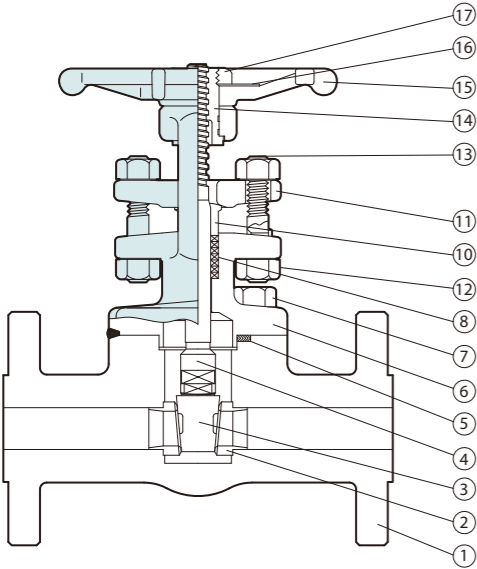

No.	Parts	Material	A.S.T.M.
1	Body	Forged Steel	A105N
2	Seat Ring	Stellite 6 faced A276-410	
3	Wedge	13Cr Stainless Steel	A217-CA15
4	Stem	13Cr Stainless Steel	A276-410
5	Gasket	304 Spiral Wound Graphite	
6	Bonnet	Forged Steel	A105N
7	Bonnet Bolt	Alloy Steel	A193-B7
8	Gland Packing	Graphoil	
10	Gland	Stainless Steel	A276-316
11	Gland Flange	Forged Steel	A105
12	Gland Nut	Carbon Steel	A194-2H
13	Gland Bolt	Stainless Steel	A193-B6
14	Yoke Sleeve	13Cr Stainless Steel	A582-416
15	Handwheel	Malleable Iron	A47
16	Name Plate	Aluminum	
17	Handwheel Nut	Carbon Steel	A563A

GATE VALVES – BOLTED / WELDED BONNET – REDUCED PORT

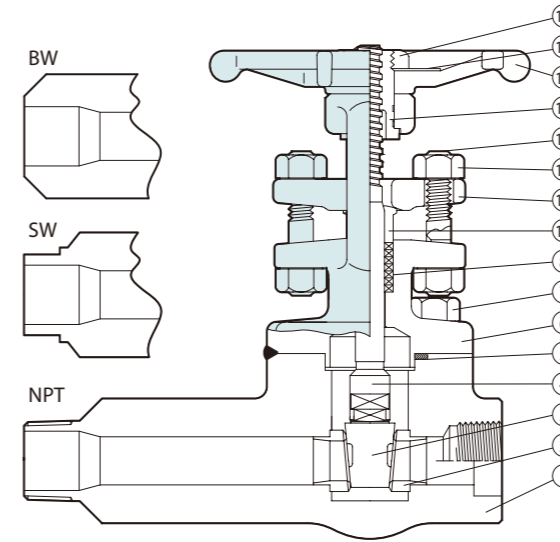

No.	Parts	Material	A.S.T.M.
1	Body	Forged Steel	A105N
2	Seat Ring	Stellite 6 faced A276-410	
3	Wedge	13Cr Stainless Steel	A217-CA15
4	Stem	13Cr Stainless Steel	A276-410
5	Gasket	304 Spiral Wound Graphite	
6	Bonnet	Forged Steel	A105N
7	Bonnet Bolt	Alloy Steel	A193-B7
8	Gland Packing	Graphoil	
10	Gland	Stainless Steel	A276-316
11	Gland Flange	Forged Steel	A105
12	Gland Nut	Carbon Steel	A194-2H
13	Gland Bolt	Stainless Steel	A193-B6
14	Yoke Sleeve	13Cr Stainless Steel	A582-416
15	Handwheel	Malleable Iron	A47
16	Name Plate	Aluminum	
17	Handwheel Nut	Carbon Steel	A563A

CLASS 150 / 300 / 600 - API 602 / ASME B16.34

Unit: mm (inch)

Port	Valve Size	Handwheel Diameter	Face to Face			Center to Top (Open)			Dia. of Port Openings	Weight Kg (Lb)		
			Class 150	Class 300	Class 600	Class 150	Class 300	Class 600		Class 150	Class 300	Class 600
Full	1/2	86 (3.39)	108 (6.57)	140 (5.95)	165 (6.50)	167 (6.57)	151 (5.95)	151 (5.95)	13.0 (0.51)	3.1 (6.8)	4.0 (8.8)	4.6 (10.1)
	3/4	99 (3.90)	117 (7.48)	152 (7.48)	190 (7.50)	190 (7.48)	190 (7.48)	190 (7.48)	18.0 (0.71)	4.7 (10.4)	6.0 (13.2)	6.6 (14.6)
	1	124 (4.88)	127 (9.49)	165 (9.09)	216 (8.50)	241 (9.49)	231 (9.09)	241 (9.49)	31.0 (1.22)	8.7 (19.2)	11 (24.3)	12.2 (26.9)
	1 1/2	138 (5.43)	165 (10.7)	190 (10.7)	241 (9.50)	271 (10.7)	271 (10.7)	271 (10.7)	37.0 (1.46)	12.2 (26.9)	14 (30.9)	15.8 (34.8)
	2	157 (6.18)	178 (13.2)	216 (12.6)	292 (11.50)	335 (13.2)	319 (12.6)	335 (13.2)	50.8 (2.00)	17.8 (39.2)	19 (41.9)	22.5 (49.6)

CLASS 600 / 800 - API 602 / ASME B16.34

Unit: mm (inch)

Port	Valve Size	Handwheel Diameter	End to End	Center to Male End	Center to Top (Open)	Dia. of Port Openings	Weight Kg (Lb)
Reduced	1/2	86 (3.39)	142 (5.59)	104 (4.10)	145 (5.71)	9.8 (0.39)	2.0 (4.4)
	3/4	86 (3.39)	157 (6.18)	114 (4.49)	151 (5.95)	13.0 (0.51)	3.4 (7.5)
	1	99 (3.90)	165 (6.50)	114 (4.49)	190 (7.48)	18.0 (0.71)	5.8 (12.8)
	1 1/2	124 (4.88)	193 (7.60)	135 (5.32)	241 (9.49)	31.0 (1.22)	8.5 (18.7)
	2	138 (5.43)	212 (8.35)	146 (5.75)	271 (10.67)	37.0 (1.46)	11.7 (25.8)

CLASS 1500 - API 602 / ASME B16.34

Unit: mm (inch)

Port	Valve Size	Handwheel Diameter	End to End	Center to Male End	Center to Top (Open)	Dia. of Port Openings	Weight Kg (Lb)
Reduced	1/2	86 (3.39)	157 (6.18)	114 (4.49)	153 (6.02)	9.8 (0.39)	3.4 (7.5)
	3/4	99 (3.90)	165 (6.50)	114 (4.49)	190 (7.58)	13.0 (0.51)	5.8 (12.8)
	1	124 (4.88)	193 (7.60)	135 (5.32)	230 (9.06)	18.0 (0.71)	8.5 (18.7)
	1 1/2	138 (5.43)	212 (8.35)	146 (5.75)	272 (10.71)	31.0 (1.22)	11.7 (25.8)
	2	157 (6.18)	264 (10.39)	189 (7.44)	325 (12.80)	37.0 (1.46)	22.5 (50.0)

GATE VALVES – INTEGRALLY REINFORCED EXTENDED BODY (IREB) - REDUCED PORT

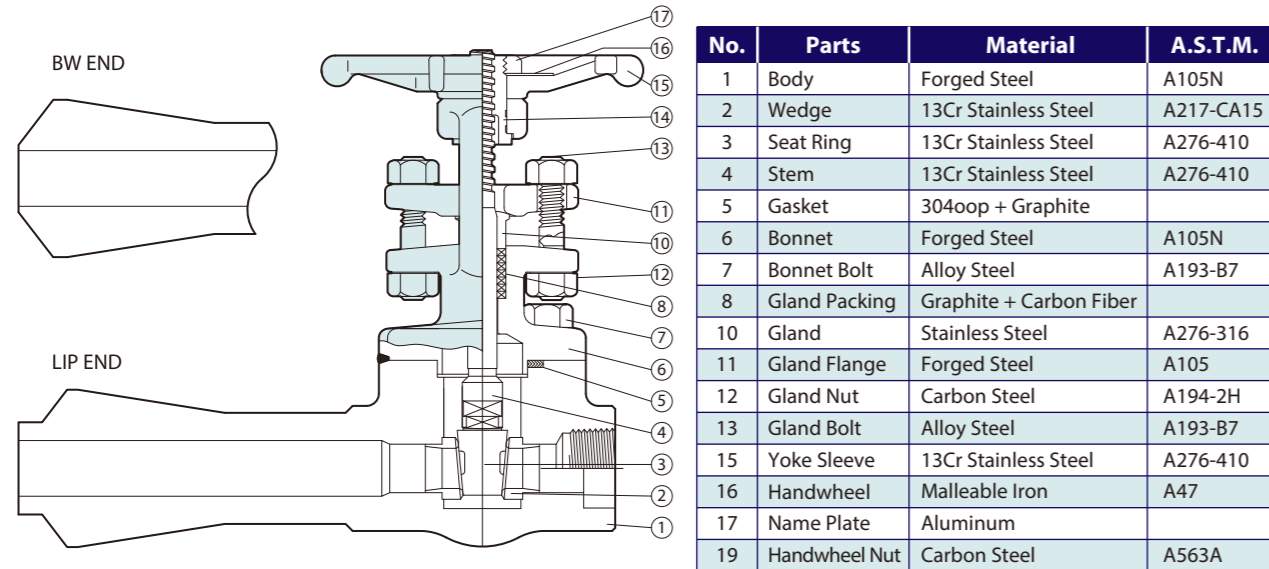

CLASS 800– API 602 / ASME B16.34

Unit: mm (inch)

Port	Valve Size	Handwheel Diameter	End to End	Center to Male End	Center to Top (Open)	Dia. of Port Openings	Weight Kg (Lb)
Reduced	1/2	102 (4.02)	206 (8.11)	168 (6.61)	145 (5.71)	9.5 (0.37)	2.1 (4.6)
	3/4	102 (4.02)	216 (8.50)	173 (6.81)	151 (5.94)	12.7 (0.50)	2.8 (6.2)
	1	114 (4.49)	232 (9.13)	181 (7.13)	190 (7.48)	18.0 (0.71)	4.4 (9.7)
	1-1/2	140 (5.51)	247 (9.72)	189 (7.44)	241 (9.49)	31.0 (1.22)	8.1 (17.9)
	2	165 (6.50)	263 (10.35)	197 (7.76)	271 (10.67)	37.0 (1.45)	10.5 (23.1)

CLASS 1500– API 602 / ASME B16.34

Unit: mm (inch)

Port	Valve Size	Handwheel Diameter	End to End	Center to Male End	Center to Top (Open)	Dia. of Port Openings	Weight Kg (Lb)
Reduced	1/2	102 (4.02)	216 (8.50)	173 (6.81)	151 (5.94)	9.5 (0.37)	2.8 (6.2)
	3/4	114 (4.49)	232 (9.13)	181 (7.13)	190 (7.48)	12.7 (0.50)	4.4 (9.7)
	1	140 (5.51)	247 (9.72)	189 (7.44)	241 (9.49)	18.0 (0.71)	8.1 (17.9)
	1-1/2	165 (6.50)	263 (10.35)	197 (7.76)	271 (10.67)	31.0 (1.22)	10.5 (23.1)

GATE VALVES – RING JOINT BONNET – REDUCED / FULL PORT

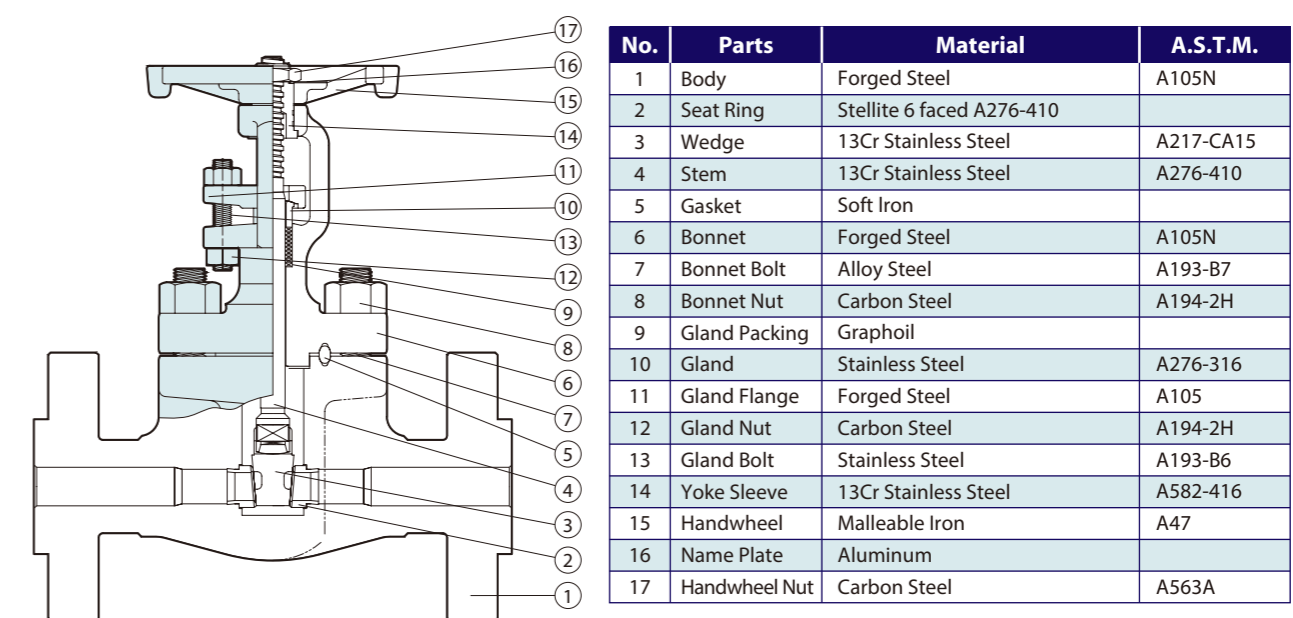

CLASS 1500 - API 602 / ASME B16.34

Unit: mm (inch)

Port	Valve Size	Handwheel Diameter	Face to Face	Center to Top (Open)	Dia. of Port Openings	Weight Kg (Lb)
Reduced	1/2	124 (4.88)	216 (8.50)	284 (11.18)	12.7 (0.50)	10 (22)
	3/4	124 (4.88)	229 (9.00)	284 (11.18)	12.7 (0.50)	14 (31)
	1	124 (4.88)	254 (10.00)	332 (13.07)	18.0 (0.71)	17 (38)
	1 1/2	200 (7.88)	305 (12.00)	390 (15.35)	31.8 (1.25)	33 (73)
	2	250 (9.84)	368 (14.25)	480 (18.90)	31.8 (1.25)	55 (121)

CLASS 2500 - ASME B16.34

Unit: mm (inch)

Port	Valve Size	Handwheel Diameter	Face to Face	Center to Top (Open)	Dia. of Port Openings	Weight Kg (Lb)
Full	1/2	124 (4.88)	264 (10.38)	311 (12.24)	12.7 (0.50)	18 (40)
	3/4	124 (4.88)	273 (10.75)	311 (12.24)	12.7 (0.50)	19 (42)
	1	200 (7.88)	308 (12.12)	388 (15.27)	18.0 (0.71)	35 (77)
	1 1/2	200 (7.88)	384 (15.12)	430 (16.93)	25.4 (1.00)	54 (119)
	2	250 (9.84)	451 (17.75)	480 (18.90)	31.8 (1.25)	82 (181)

GATE VALVES – SEAL WELDED BONNET – REDUCED / FULL PORT

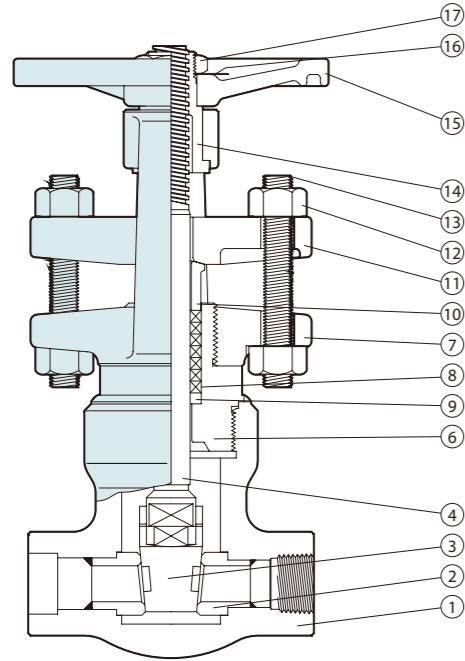

No.	Parts	Material	A.S.T.M.
1	Body	Forged Steel	A105N
2	Seat Ring	Stellite 6 faced A105	
3	Wedge	Stellite 6 faced A276-410	
4	Stem	13Cr Stainless Steel	A276-410
6	Bonnet	Forged Steel	A105N
7	Yoke	Forged Steel	A105N
8	Gland Packing	Graphoil	
9	Packing Ring	Stainless Steel	A276-316
10	Gland	Stainless Steel	A276-316
11	Gland Flange	Forged Steel	A105
12	Gland Nut	Carbon Steel	A194-2H
13	Gland Bolt	Alloy Steel	A193-B7
14	Yoke Sleeve	High Tension Brass	
15	Handwheel	Malleable Iron	A47
16	Name Plate	Aluminum	
17	Handwheel Nut	Carbon Steel	A563A

CLASS 1500 - ASME B16.34

Unit: mm (inch)

Port	Valve Size	Handwheel Diameter	End to End	Center to Top (Open)	Dia. of Port Openings	Weight Kg (Lb)
Reduced	1/2	140 (5.51)	110 (4.33)	235 (9.25)	12 (0.47)	5 (11)
	3/4	140 (5.51)	110 (4.33)	235 (9.25)	12 (0.47)	5 (11)
	1	140 (5.51)	127 (5.00)	267 (10.51)	16 (0.63)	7 (15)
	1 1/4	200 (7.87)	155 (6.10)	320 (12.60)	20 (0.79)	13 (29)
	1 1/2	200 (7.87)	155 (6.10)	320 (12.60)	20 (0.79)	13 (29)
	2	230 (9.06)	210 (8.27)	361 (14.21)	32 (1.26)	23 (51)
Full	1/2	140 (5.51)	110 (4.33)	235 (9.25)	12 (0.47)	5 (11)
	3/4	140 (5.51)	127 (5.00)	267 (10.51)	16 (0.63)	7 (15)
	1	200 (7.87)	155 (6.10)	320 (12.60)	20 (0.79)	13 (29)
	1 1/4	230 (9.06)	210 (8.27)	361 (14.21)	32 (1.26)	23 (51)
	1 1/2	230 (9.06)	210 (8.27)	361 (14.21)	32 (1.26)	23 (51)
	2	250 (9.84)	229 (9.02)	468 (18.43)	43 (1.69)	37 (82)

CLASS 2500 - ASME B16.34

Unit: mm (inch)

Port	Valve Size	Handwheel Diameter	End to End	Center to Top (Open)	Dia. of Port Openings	Weight Kg (Lb)
Full	1/2	140 (5.51)	110 (4.33)	227 (8.94)	12 (0.47)	5 (11)
	3/4	200 (7.87)	127 (5.00)	270 (10.63)	16 (0.63)	8 (18)
	1	230 (9.06)	155 (6.10)	324 (12.76)	21 (0.83)	13 (30)
	1 1/4	250 (9.84)	210 (8.27)	390 (15.35)	32 (1.26)	23 (52)
	1 1/2	250 (9.84)	210 (8.27)	390 (15.35)	32 (1.26)	23 (52)
	2	315 (12.4)	229 (9.02)	487 (19.17)	38 (1.50)	38 (84)

GATE VALVES – PRESSURE SEAL BONNET – FULL PORT

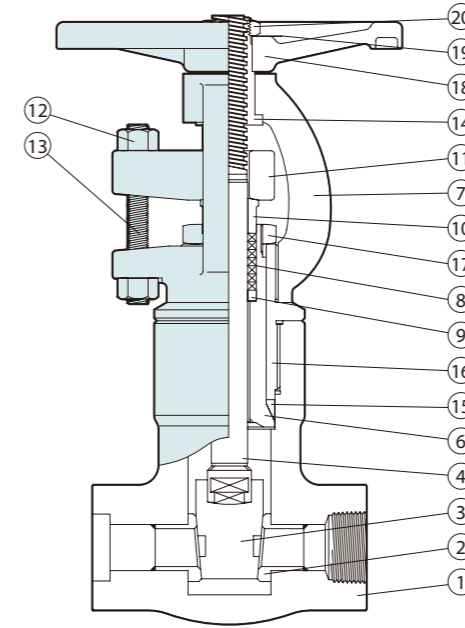

No.	Parts	Material	A.S.T.M.
1	Body	Forged Steel	A105N
2	Seat Ring	Stellite 6 faced A105	
3	Wedge	Stellite 6 faced A276-410	
4	Stem	13Cr Stainless Steel	A276-410
6	Bonnet	Forged Steel	A105N
7	Yoke	Forged Steel	A105N
8	Gland Packing	Graphoil	
9	Packing Ring	Stainless Steel	A276-316
10	Gland	Stainless Steel	A276-316
11	Gland Flange	Forged Steel	A105
13	Gland Nut	Carbon Steel	A194-2H
12	Gland Bolt	Alloy Steel	A193-B7
14	Yoke Sleeve	High Tension Brass	
15	Gasket	Soft Iron	
16	Bonnet Guide	Forged Steel	A105N
17	Bonnet Nut	Carbon Steel	
18	Handwheel	Malleable Iron	A47
19	Name Plate	Aluminum	
20	Handwheel Nut	Carbon Steel	A563A

CLASS 1500 / 2500 - ASME B16.34

Unit: mm (inch)

Port	Valve Size	Handwheel Diameter	End to End	Center to Top (Open)	Dia. of Port Openings	Weight Kg (Lb)
Full	1/2	200 (7.87)	155 (6.10)	311 (12.24)	12 (0.47)	14 (31)
	3/4	200 (7.87)	155 (6.10)	311 (12.24)	16 (0.63)	14 (31)
	1	230 (9.06)	210 (8.27)	364 (14.33)	20 (0.79)	23 (51)
	1 1/2	250 (9.84)	229 (9.02)	428 (16.85)	32 (1.26)	34 (75)
	2	315 (12.4)	235 (9.25)	473 (18.62)	43 (1.69)	43 (95)

GLOBE VALVES - BOLTED / WELDED BONNET - REDUCED / FULL PORT

GLOBE VALVES - BOLTED / WELDED BONNET - REDUCED PORT

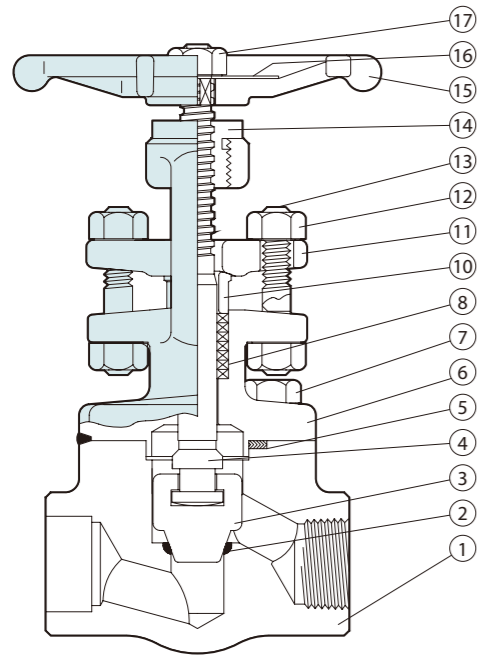

No.	Parts	Material	A.S.T.M.
1	Body	Forged Steel	A105N
2	Seat	Integral Hardfaced Stellite 6	
3	Disc	13Cr Stainless Steel	A217-CA15
4	Stem	13Cr Stainless Steel	A276-410
5	Gasket	304 Spiral Wound Graphite	
6	Bonnet	Forged Steel	A105N
7	Bonnet Bolt	Alloy Steel	A193-B7
8	Gland Packing	Graphoil	
10	Gland	Stainless Steel	A276-316
11	Gland Flange	Forged Steel	A105
12	Gland Nut	Carbon Steel	A194-2H
13	Gland Bolt	Stainless Steel	A193-B6
14	Yoke Bush	13Cr Stainless Steel	A582-416
15	Handwheel	Malleable Iron	A47
16	Name Plate	Aluminum	
17	Handwheel Nut	Carbon Steel	A194-2H

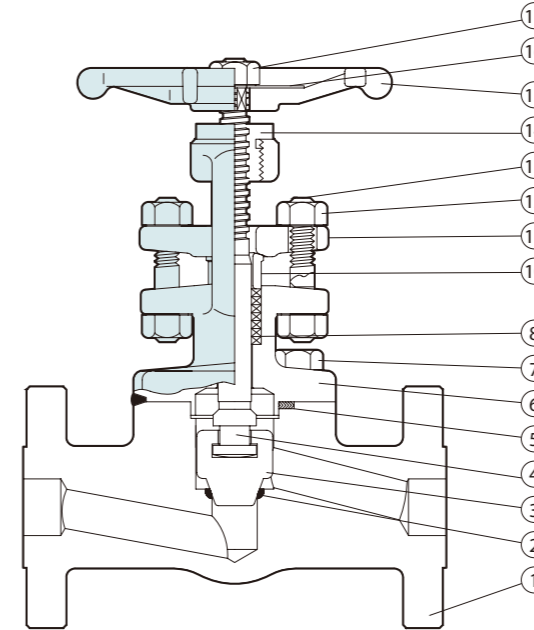

No.	Parts	Material	A.S.T.M.
1	Body	Forged Steel	A105N
2	Seat	Integral Hardfaced Stellite 6	
3	Disc	13Cr Stainless Steel	A217-CA15
4	Stem	13Cr Stainless Steel	A276-410
5	Gasket	304 Spiral Wound Graphite	
6	Bonnet	Forged Steel	A105N
7	Bonnet Bolt	Alloy Steel	A193-B7
8	Gland Packing	Graphoil	
10	Gland	Stainless Steel	A276-316
11	Gland Flange	Forged Steel	A105
12	Gland Nut	Carbon Steel	A194-2H
13	Gland Bolt	Stainless Steel	A193-B6
14	Yoke Bush	13Cr Stainless Steel	A582-416
15	Handwheel	Malleable Iron	A47
16	Name Plate	Aluminum	
17	Handwheel Nut	Carbon Steel	A194-2H

CLASS 600 / 800 - API 602 / ASME B16.34 / BS 5352

Unit: mm (inch)

Port	Valve Size	Handwheel Diameter	End to End	Center to Top (Open)	Dia. of Port Openings	Weight Kg (Lb)
	3/4	86 (3.39)	86 (3.39)	152 (5.98)	12.7 (0.50)	2.1 (4.6)
	1	99 (3.90)	102 (4.02)	188 (7.40)	17.5 (0.69)	2.9 (6.4)
	1 1/4	124 (4.88)	152 (5.98)	219 (8.62)	22.5 (0.89)	6.4 (14.1)
	1 1/2	124 (4.88)	152 (5.98)	219 (8.62)	29.5 (1.16)	6.4 (14.1)
	2	138 (5.43)	172 (6.77)	260 (10.24)	35.0 (1.38)	9.7 (21.4)
Full	1/2	86 (3.39)	86 (3.39)	157 (6.18)	12.7 (0.50)	2.1 (4.6)
	3/4	99 (3.90)	102 (4.02)	190 (7.48)	17.5 (0.69)	2.9 (6.4)
	1	124 (4.88)	152 (5.98)	225 (8.86)	23.0 (0.91)	6.4 (14.1)
	1 1/4	138 (5.43)	172 (6.77)	267 (10.51)	29.5 (1.16)	9.7 (21.4)
	1 1/2	138 (5.43)	172 (6.77)	267 (10.51)	35.0 (1.38)	9.7 (21.4)
	2	157 (6.18)	218 (8.58)	324 (12.76)	45.5 (1.79)	14.0 (30.9)

CLASS 1500 - API 602 / ASME B16.34 / BS 5352

Unit: mm (inch)

Port	Valve Size	Handwheel Diameter	End to End	Center to Top (Open)	Dia. of Port Openings	Weight Kg (Lb)
	3/4	99 (3.90)	102 (4.02)	185 (7.28)	12.7 (0.50)	3.4 (7.5)
	1	124 (4.88)	152 (5.98)	210 (8.27)	17.5 (0.69)	6.5 (14.3)
	1 1/4	138 (5.43)	172 (6.77)	245 (9.65)	22.5 (0.89)	9.6 (21.2)
	1 1/2	138 (5.43)	172 (6.77)	245 (9.65)	29.5 (1.16)	9.6 (21.2)
	2	157 (6.18)	210 (8.27)	308 (12.13)	35.0 (1.38)	14.0 (30.9)

CLASS 150 / 300 / 600 - API 602 / ASME B16.34 / BS 5352

Unit: mm (inch)

Port	Valve Size	Handwheel Diameter	Face to Face			Center to Top (Open)	Dia. of Port Openings	Weight Kg (Lb)		
			Class 150	Class 300	Class 600			Class 150	Class 300	Class 600
Reduced	1/2	86 (3.39)	108 (4.25)	152 (6.00)	165 (6.50)	146 (5.75)	9.5 (0.37)	2.5 (5.5)	3.0 (6.6)	3.3 (7.3)
	3/4	86 (3.39)	117 (4.62)	178 (7.00)	190 (7.50)	152 (5.98)	12.7 (0.50)	3.1 (6.8)	4.0 (8.8)	4.6 (10.1)
	1	99 (3.90)	127 (5.00)	203 (8.00)	216 (8.50)	188 (7.40)	17.5 (0.69)	4.9 (10.8)	6.2 (13.7)	6.8 (15.0)
	1 1/2	124 (4.88)	165 (6.50)	229 (9.00)	241 (9.50)	219 (8.62)	29.5 (1.16)	9.2 (20.3)	11.4 (25.1)	12.7 (28.0)
	2	138 (5.43)	203 (8.00)	267 (10.50)	292 (11.50)	260 (10.24)	35.0 (1.38)	13.9 (30.7)	15.4 (34.0)	16.3 (35.9)

CLASS 1500 - API 602 / ASME B16.34 / BS 5352

Unit: mm (inch)

Port	Valve Size	Handwheel Diameter	Face to Face	Center to Top (Open)	Dia. of Port Openings	Weight Kg (Lb)
	3/4	99 (3.90)	229 (9.00)	185 (7.28)	12.7 (0.50)	9.0 (19.9)
	1	124 (4.88)	254 (10.00)	210 (8.27)	17.5 (0.69)	14.5 (32.0)
	1 1/2	138 (5.43)	305 (12.00)	245 (9.65)	29.5 (1.16)	23.3 (51.4)
	2	157 (6.18)	368 (14.25)	308 (12.13)	35.0 (1.38)	35.5 (78.3)

GLOBE VALVES – BOLTED / WELDED BONNET – FULL PORT

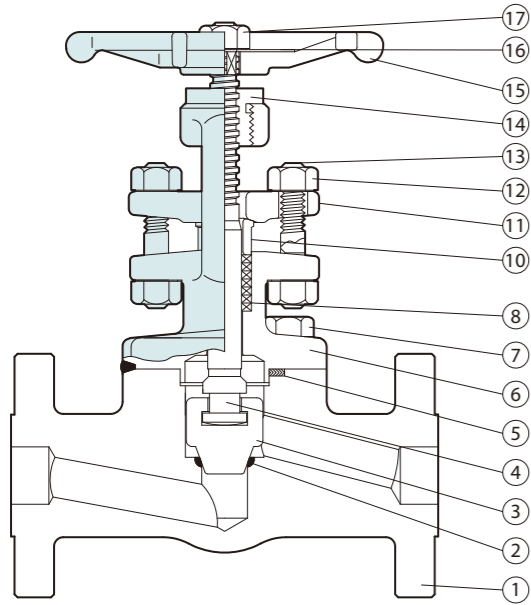

No.	Parts	Material	A.S.T.M.
1	Body	Forged Steel	A105N
2	Seat Ring	Stellite 6 faced A276-410	
3	Wedge	13Cr Stainless Steel	A217-CA15
4	Stem	13Cr Stainless Steel	A276-410
5	Gasket	304 Spiral Wound Graphite	
6	Bonnet	Forged Steel	A105N
7	Bonnet Bolt	Alloy Steel	A193-B7
8	Gland Packing	Graphoil	
10	Gland	Stainless Steel	A276-316
11	Gland Flange	Forged Steel	A105
12	Gland Nut	Carbon Steel	A194-2H
13	Gland Bolt	Stainless Steel	A193-B6
14	Yoke Sleeve	13Cr Stainless Steel	A582-416
15	Handwheel	Malleable Iron	A47
16	Name Plate	Aluminum	
17	Handwheel Nut	Carbon Steel	A563A

CLASS 150 / 300 / 600 - API 602 / ASME B16.34 / BS 5352

Unit: mm (inch)

Port	Valve Size	Handwheel Diameter	Face to Face			Center to Top (Open)			Dia. of Port Openings	Weight Kg (Lb)		
			Class 150	Class 300	Class 600	Class 150	Class 300	Class 600		Class 150	Class 300	Class 600
Full	1/2	86 (3.39)	108 (4.25)	152 (6.00)	165 (6.50)	168 (6.61)	152 (5.98)	152 (5.98)	13.0 (0.51)	3.1 (6.80)	4.0 (8.80)	4.6 (10.1)
	3/4	99 (3.90)	117 (4.62)	178 (7.00)	190 (7.50)	188 (7.40)	188 (7.40)	188 (7.40)	17.5 (0.69)	4.9 (10.8)	6.2 (13.7)	6.8 (15.0)
	1	124 (4.88)	127 (5.00)	203 (8.00)	216 (8.50)	219 (8.62)	219 (8.62)	219 (8.62)	29.5 (1.16)	9.2 (20.3)	11.4 (25.1)	12.7 (28.0)
	1 1/2	138 (5.43)	165 (6.50)	229 (9.00)	241 (9.50)	260 (10.2)	260 (10.2)	260 (10.2)	35.0 (1.38)	13.9 (30.7)	15.4 (34.0)	16.3 (35.9)
	2	157 (6.18)	203 (8.00)	267 (10.5)	292 (11.50)	324 (12.8)	324 (12.8)	324 (12.8)	45.5 (1.79)	18.7 (41.2)	21.5 (47.4)	23.6 (52.0)

GLOBE VALVES – RING JOINT BONNET – REDUCED / FULL PORT

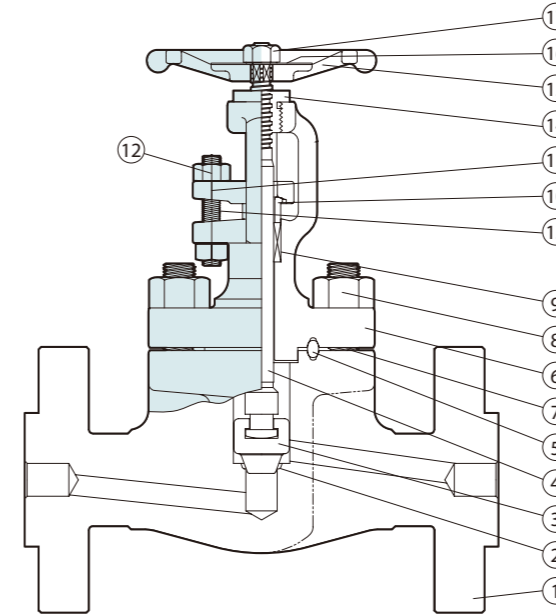

No.	Parts	Material	A.S.T.M.
1	Body	Forged Steel	A105N
2	Seat	Integral Hardfaced Stellite 6	
3	Disc	13Cr Stainless Steel	A217-CA15
4	Stem	13Cr Stainless Steel	A276-410
5	Gasket	Soft Iron	
6	Bonnet	Forged Steel	A105N
7	Bonnet Bolt	Alloy Steel	A193-B7
8	Bonnet Nut	Carbon Steel	A194-2H
9	Gland Packing	Graphoil	
10	Gland	Stainless Steel	A276-316
11	Gland Flange	Forged Steel	A105
12	Gland Nut	Carbon Steel	A194-2H
13	Gland Bolt	Stainless Steel	A193-B6
14	Yoke Bush	13Cr Stainless Steel	A582-416
15	Handwheel	Malleable Iron	A47
16	Name Plate	Aluminum	
17	Handwheel Nut	Carbon Steel	A194-2H

CLASS 1500 - API 602 / ASME B16.34 / BS 5352

Unit: mm (inch)

Port	Valve Size	Handwheel Diameter	Face to Face	Center to Top (Open)	Dia. of Port Openings	Weight Kg (Lb)
Reduced	1/2	124 (4.88)	216 (8.50)	286 (11.26)	10 (0.39)	11 (24)
	3/4	124 (4.88)	229 (9.00)	286 (11.26)	15 (0.59)	15 (33)
	1	200 (7.88)	254 (10.00)	339 (13.35)	18 (0.71)	18 (40)
	1 1/2	200 (7.88)	305 (12.00)	386 (15.20)	28 (1.10)	35 (77)
	2	250 (9.84)	368 (14.25)	480 (18.90)	35 (1.38)	57 (126)

CLASS 2500 - ASME B16.34 / BS 5352

Unit: mm (inch)

Port	Valve Size	Handwheel Diameter	Face to Face	Center to Top (Open)	Dia. of Port Openings	Weight Kg (Lb)
Full	1/2	124 (4.88)	264 (10.38)	339 (13.35)	10 (0.39)	19 (42)
	3/4	124 (4.88)	273 (10.75)	339 (13.35)	15 (0.59)	20 (44)
	1	200 (7.88)	308 (12.12)	386 (15.20)	18 (0.71)	37 (82)
	1 1/2	200 (7.88)	384 (15.12)	439 (17.29)	28 (1.10)	57 (126)
	2	250 (9.84)	451 (17.75)	480 (18.90)	35 (1.38)	83 (183)

GLOBE VALVES – SEAL WELDED BONNET – REDUCED / FULL PORT

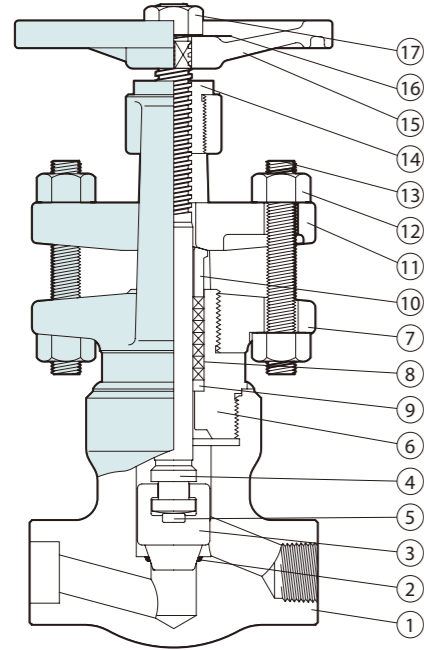

No.	Parts	Material	A.S.T.M.
1	Body	Forged Steel	A105N
2	Seat	Integral Hardfaced Stellite 6	
3	Disc	Stellite 6 faced A276-410	
4	Stem	13Cr Stainless Steel	A276-410
5	Disc Pad	Stainless Steel	A276-316
6	Bonnet	Forged Steel	A105N
7	Yoke	Forged Steel	A105N
8	Gland Packing	Graphoil	
9	Packing Ring	Stainless Steel	A276-316
10	Gland	Stainless Steel	A276-316
11	Gland Flange	Forged Steel	A105
12	Gland Nut	Carbon Steel	A194-2H
13	Gland Bolt	Alloy Steel	A193-B7
14	Yoke Bush	High Tension Brass	
15	Handwheel	Malleable Iron	A47
16	Name Plate	Aluminum	
17	Handwheel Nut	Carbon Steel	A194-2H

CLASS 1500 - ASME B16.34

Unit: mm (inch)

Port	Valve Size	Handwheel Diameter	End to End	Center to Top (Open)	Dia. of Port Openings	Weight Kg (Lb)
Reduced	1/2	140 (5.51)	110 (4.33)	232 (9.13)	9.5 (0.37)	5 (11)
	3/4	140 (5.51)	110 (4.33)	232 (9.13)	12 (0.47)	5 (11)
	1	140 (5.51)	127 (5.00)	269 (10.59)	16 (0.63)	7 (15)
	1 1/4	200 (7.87)	155 (6.10)	280 (11.02)	20 (0.79)	12 (27)
	1 1/2	200 (7.87)	155 (6.10)	280 (11.02)	27 (1.06)	12 (27)
	2	230 (9.06)	210 (8.27)	390 (15.35)	32 (1.26)	21 (46)
Full	1/2	140 (5.51)	110 (4.33)	232 (9.13)	12 (0.47)	5 (11)
	3/4	140 (5.51)	127 (5.00)	269 (10.59)	16 (0.63)	7 (15)
	1	200 (7.87)	155 (6.10)	322 (12.68)	20 (0.79)	12 (27)
	1 1/4	230 (9.06)	210 (8.27)	390 (15.35)	27 (1.06)	21 (46)
	1 1/2	230 (9.06)	210 (8.27)	390 (15.35)	32 (1.26)	21 (46)
	2	250 (9.84)	229 (9.02)	471 (18.54)	39 (1.54)	35 (77)

CLASS 2500 - ASME B16.34

Unit: mm (inch)

Port	Valve Size	Handwheel Diameter	End to End	Center to Top (Open)	Dia. of Port Openings	Weight Kg (Lb)
Full	1/2	140 (5.51)	110 (4.33)	238 (9.37)	10 (0.39)	5 (11)
	3/4	200 (7.87)	127 (5.00)	282 (11.10)	13 (0.51)	8 (18)
	1	230 (9.06)	155 (6.10)	322 (12.68)	18 (0.71)	13 (29)
	1 1/4	250 (9.84)	210 (8.27)	395 (15.55)	23 (0.91)	22 (49)
	1 1/2	250 (9.84)	210 (8.27)	395 (15.55)	26 (1.02)	22 (49)
	2	315 (12.4)	229 (9.02)	483 (19.02)	35 (1.38)	37 (82)

CLASS 4500 - ASME B16.34

Unit: mm (inch)

Port	Valve Size	Handwheel Diameter	End to End	Center to Top (Open)	Dia. of Port Openings	Weight Kg (Lb)
Full	1/2	200 (7.87)	127 (5.00)	282 (11.10)	7 (0.28)	8 (18)
	3/4	230 (9.06)	155 (6.10)	322 (12.68)	11 (0.43)	13 (29)
	1	250 (9.84)	210 (8.27)	395 (15.55)	14 (0.55)	22 (49)
	1 1/4	315 (12.4)	229 (9.02)	475 (18.70)	22 (0.87)	37 (82)
	1 1/2	315 (12.4)	229 (9.02)	475 (18.70)	22 (0.87)	37 (82)
	2	315 (12.4)	250 (9.84)	493 (19.41)	25 (0.98)	48 (106)

GLOBE VALVES – PRESSURE SEAL BONNET - FULL PORT

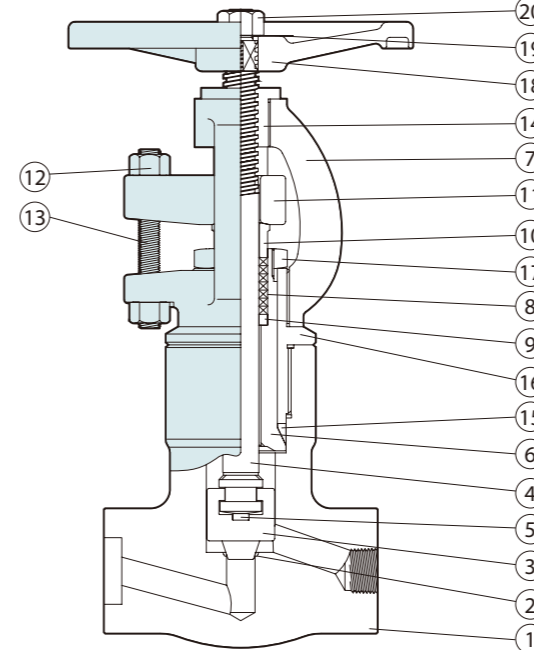

No.	Parts	Material	A.S.T.M.
1	Body	Forged Steel	A105N
2	Seat	Integral Hardfaced Stellite 6	
3	Disc	Stellite 6 faced A276-410	
4	Stem	13Cr Stainless Steel	A276-410
5	Disc Pad	Stainless Steel	A276-316
6	Bonnet	Forged Steel	A105N
7	Yoke	Forged Steel	A105N
8	Gland Packing	Graphoil	
9	Packing Ring	Stainless Steel	A276-316
10	Gland	Stainless Steel	A276-316
11	Gland Flange	Forged Steel	A105
12	Gland Nut	Carbon Steel	A194-2H
13	Gland Bolt	Alloy Steel	A193-B7
14	Yoke Bush	High Tension Brass	
15	Gasket	Soft Iron	
16	Bonnet Guide	Forged Steel	A105N
17	Bonnet Nut	Carbon Steel	
18	Handwheel	Malleable Iron	A47
19	Name Plate	Aluminum	
20	Handwheel Nut	Carbon Steel	A194-2H

CLASS 1500 - ASME B16.34

Unit: mm (inch)

Port	Valve Size	Handwheel Diameter	End to End	Center to Top (Open)	Dia. of Port Openings	Weight Kg (Lb)
Full	1/2	140 (5.51)	155 (6.10)	312 (12.28)	12 (0.47)	11 (24)
	3/4	140 (5.51)	155 (6.10)	312 (12.28)	16 (0.63)	11 (24)
	1	200 (7.87)	210 (8.27)	373 (14.69)	20 (0.79)	17 (38)
	1 1/2	230 (9.06)	229 (9.02)	444 (17.48)	32 (1.26)	29 (64)
	2	250 (9.84)	235 (9.25)	504 (19.84)	39 (1.54)	43 (95)

CLASS 2500 - ASME B16.34

Unit: mm (inch)

Port	Valve Size	Handwheel Diameter	End to End	Center to Top (Open)	Dia. of Port Openings	Weight Kg (Lb)
Full	1/2	140 (5.51)	155 (6.10)	312 (12.28)	10 (0.39)	11 (24)
	3/4	140 (5.51)	210 (8.27)	312 (12.28)	13 (0.51)	17 (38)
	1	200 (7.87)	229 (9.02)	373 (14.69)	18 (0.71)	29 (64)
	1 1/2	230 (9.06)	235 (9.25)	444 (17.48)	26 (1.02)	43 (95)
	2	250 (9.84)	235 (9.25)	477 (18.78)	35 (1.38)	43 (95)

CLASS 4500 - ASME B16.34

Unit: mm (inch)

Port	Valve Size	Handwheel Diameter	End to End	Center to Top (Open)	Dia. of Port Openings	Weight Kg (Lb)
Full	1/2	200 (7.87)	210 (8.27)	312 (12.28)	7 (0.28)	17 (38)
	3/4	200 (7.87)	210 (8.27)	373 (14.69)	11 (0.43)	18 (40)
	1	230 (9.06)	229 (9.02)	444 (17.48)	14 (0.55)	29 (64)
	1 1/2	250 (9.84)	235 (9.25)	477 (18.78)	22 (0.87)	43 (95)
	2	315 (12.4)	250 (9.84)	546 (21.50)	25 (0.98)	50 (110)

GLOBE VALVES - BONNETLESS - FULL PORT

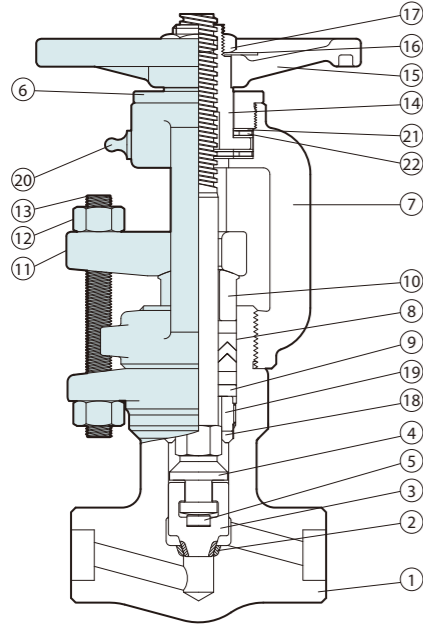

No.	Parts	Material	A.S.T.M.
1	Body	Forged Steel	A105N
2	Seat	Integral Hardfaced Stellite 6	
3	Disc	Stellite 6 faced A276-410	
4	Stem	13Cr Stainless steel	A276-410
5	Disc Pad	Stainless Steel	A276-316
6	Yoke Cap	13Cr Stainless steel	A276-410
7	Yoke	Forged Steel	A105N
8	Gland Packing	Graphoil	
9	Paking Ring	Stainless Steel	A276-316
10	Gland	Stainless Steel	A276-316
11	Gland Flange	Forged Steel	A105
12	Gland Nut	Carbon Steel	A194-2H
13	Gland Bolt	Alloy Steel	A193-B7
14	Yoke Sleeve	13Cr Stainless steel	A276-410
15	Handwheel	Malleable Iron	A47
16	Name Plate	Stainless Steel	A240-304
17	Handwheel Nut	Carbon Steel	A563A
18	Back Seat Ring	Stainless Steel	A276-316
19	Back Seat Bushing	13Cr Stainless steel	A276-410
20	Grease Nipple	Carbon Steel	
21	Needle Bearing Washer	-	
22	Needle Bearing	-	

CLASS 1500 / 1690 - ASME B 16.34

Unit: mm (inch)

Port	Valve Size	Handwheel Diameter	End to End	Center to Top (Open)	Dia. of Port Openings	Weight Kg (Lb)
Full	1/2	140 (5.51)	110 (4.33)	230 (9.06)	12 (0.43)	10 (22)
	3/4	140 (5.51)	127 (5.00)	252 (9.92)	16 (0.63)	11 (25)
	1	200 (7.87)	155 (6.10)	258 (10.16)	20 (0.79)	12 (27)
	1-1/2	230 (9.06)	210 (8.27)	369 (14.53)	32 (1.26)	36 (80)
	2	250 (9.84)	229 (9.02)	385 (15.16)	39 (1.54)	63 (139)

CLASS 2500 / 2680 - ASME B 16.34

Unit: mm (inch)

Port	Valve Size	Handwheel Diameter	End to End	Center to Top (Open)	Dia. of Port Openings	Weight Kg (Lb)
Full	1/2	140 (5.51)	110 (4.33)	232 (9.13)	10 (0.39)	10 (22)
	3/4	140 (5.51)	127 (5.00)	256 (10.08)	13 (0.51)	12 (27)
	1	200 (7.87)	155 (6.10)	275 (10.83)	18 (0.71)	25 (55)
	1-1/2	250 (9.84)	210 (8.27)	379 (14.92)	26 (1.02)	43 (95)
	2	315 (12.40)	229 (9.02)	429 (16.89)	35 (1.38)	65 (143)

CLASS 4500 - ASME B 16.34

Unit: mm (inch)

Port	Valve Size	Handwheel Diameter	End to End	Center to Top (Open)	Dia. of Port Openings	Weight Kg (Lb)
Full	1/2	140 (5.51)	127 (5.00)	251 (9.88)	11 (0.43)	20 (44)
	3/4	140 (5.51)	127 (5.00)	254 (10.00)	11 (0.43)	20 (44)
	1	200 (7.87)	165 (6.50)	288 (11.34)	14 (0.55)	28 (62)
	1-1/2	250 (9.84)	250 (9.84)	394 (15.51)	25 (0.98)	67 (148)
	2	250 (9.84)	250 (9.84)	443 (17.44)	25 (0.98)	67 (148)

Y-GLOBE VALVES - BOLTED / WELDED BONNET - REDUCED / FULL PORT

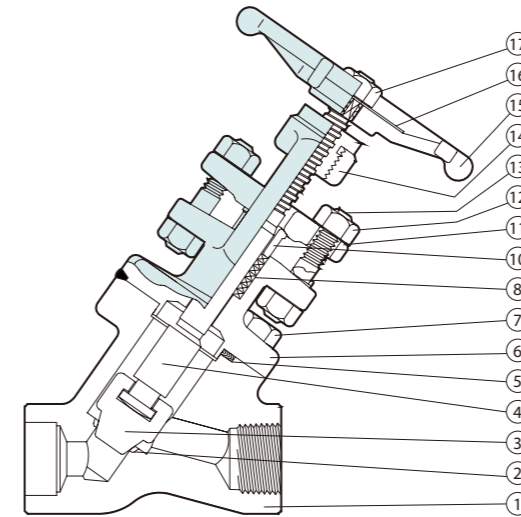

No.	Parts	Material	A.S.T.M.
1	Body	Forged Steel	A105N
2	Seat	Integral Hardfaced Stellite 6	
3	Disc	13Cr Stainless Steel	A217-CA15
4	Stem	13Cr Stainless Steel	A276-410
5	Gasket	304 Spiral Wound Graphite	
6	Bonnet	Forged Steel	A105N
7	Bonnet Bolt	Alloy Steel	A193-B7
8	Gland Packing	Graphoil	
10	Gland	Stainless Steel	A276-316
11	Gland Flange	Forged Steel	A105
12	Gland Nut	Carbon Steel	A194-2H
13	Gland Bolt	Stainless Steel	A193-B6
14	Yoke Bush	13Cr Stainless Steel	A582-416
15	Handwheel	Malleable Iron	A47
16	Name Plate	Aluminum	
17	Handwheel Nut	Carbon Steel	A194-2H

CLASS 600 / 800 - API 602 / ASME B16.34 / BS 5352

Unit: mm (inch)

Port	Valve Size	Handwheel Diameter	End to End	Center to Top (Open)	Dia. of Port Openings	Weight Kg (Lb)
Reduced	1/2	86 (3.39)	84 (3.31)	171 (6.73)	9.5 (0.37)	1.8 (4.0)
	3/4	86 (3.39)	95 (3.74)	183 (7.21)	12.7 (0.50)	2.1 (4.6)
	1	99 (3.90)	106 (4.17)	213 (8.39)	17.5 (0.69)	3.4 (7.5)
	1 1/4	124 (4.88)	137 (5.39)	259 (10.20)	22.5 (0.89)	6.4 (14.1)
	1 1/2	124 (4.88)	137 (5.39)	259 (10.20)	29.5 (1.16)	6.4 (14.1)
	2	138 (5.43)	172 (6.77)	329 (12.95)	35.0 (1.38)	9.7 (21.4)

Full	1/2	86 (3.39)	95 (3.74)	171 (6.73)	12.7 (0.50)	2.0 (4.4)
	3/4	99 (3.90)	106 (4.17)	220 (8.66)	17.5 (0.69)	4.4 (9.7)
	1	124 (4.88)	137 (5.39)	251 (9.88)	23.0 (0.91)	7.4 (16.3)
	1 1/4	138 (5.43)	172 (6.77)	325 (12.80)	29.5 (1.16)	10.9 (24.0)
	1 1/2	138 (5.43)	172 (6.77)	325 (12.80)	35.0 (1.38)	10.7 (23.6)
2	157 (6.18)	200 (7.87)	358 (14.10)	45.5 (1.79)	15.0 (33.1)	

Y-GLOBE VALVES – SEAL WELDED BONNET – FULL PORT

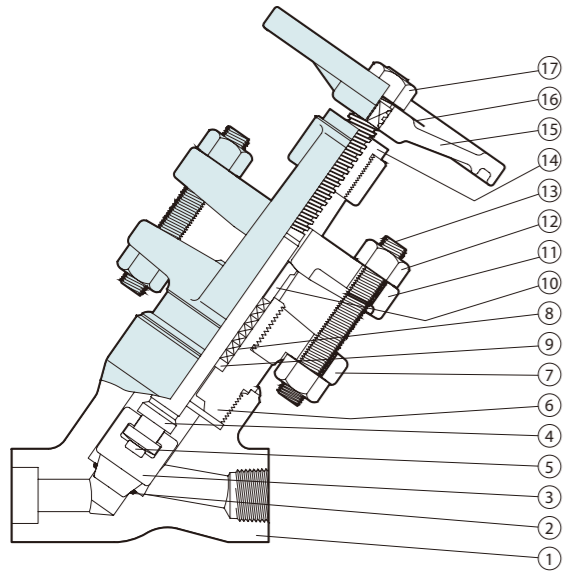

No.	Parts	Material	A.S.T.M.
1	Body	Forged Steel	A105N
2	Seat	Integral Hardfaced Stellite 6	
3	Disc	Stellite 6 faced A276-410	
4	Stem	13Cr Stainless Steel	A276-410
5	Disc Pad	Stainless Steel	A276-316
6	Bonnet	Forged Steel	A105N
7	Yoke	Forged Steel	A105N
8	Gland Packing	Graphoil	
9	Packing Ring	Stainless Steel	A276-316
10	Gland	Stainless Steel	A276-316
11	Gland Flange	Forged Steel	A105
12	Gland Nut	Carbon Steel	A194-2H
13	Gland Bolt	Alloy Steel	A193-B7
14	Yoke Bush	High Tension Brass	
15	Handwheel	Malleable Iron	A47
16	Name Plate	Aluminum	
17	Handwheel Nut	Carbon Steel	A194-2H

CLASS 1500 / 1690 - ASME B16.34

Unit: mm (inch)

Port	Valve Size	Handwheel Diameter	End to End	Center to Top (Open)	Dia. of Port Openings	Weight Kg (Lb)
Reduced	1/2	140 (5.51)	110 (4.33)	230 (9.06)	9.5 (0.37)	5 (11)
	3/4	140 (5.51)	110 (4.33)	230 (9.06)	12 (0.47)	5 (11)
	1	140 (5.51)	127 (5.00)	273 (10.75)	16 (0.63)	8 (18)
	1 1/4	200 (7.87)	155 (6.10)	328 (12.91)	20 (0.79)	21 (46)
	1 1/2	200 (7.87)	155 (6.10)	328 (12.91)	27 (1.06)	21 (46)
	2	230 (9.06)	210 (8.27)	400 (15.75)	32 (1.26)	21 (46)
Full	1/2	140 (5.51)	110 (4.33)	230 (9.06)	12 (0.47)	5 (11)
	3/4	140 (5.51)	127 (5.00)	273 (10.75)	16 (0.63)	7 (15)
	1	200 (7.87)	155 (6.10)	328 (12.91)	20 (0.79)	12 (27)
	1 1/4	230 (9.06)	210 (8.27)	400 (15.75)	27 (1.06)	21 (46)
	1 1/2	230 (9.06)	210 (8.27)	400 (15.75)	32 (1.26)	21 (46)
	2	250 (9.84)	229 (9.02)	480 (18.90)	39 (1.54)	35 (77)

CLASS 2500 / 2680 - ASME B16.34

Unit: mm (inch)

Port	Valve Size	Handwheel Diameter	End to End	Center to Top (Open)	Dia. of Port Openings	Weight Kg (Lb)
Full	1/2	140 (5.51)	110 (4.33)	248 (9.76)	10 (0.39)	5 (11)
	3/4	200 (7.87)	127 (5.00)	291 (11.46)	13 (0.51)	8 (18)
	1	230 (9.06)	155 (6.10)	333 (13.11)	18 (0.71)	13 (29)
	1 1/4	250 (9.84)	210 (8.27)	413 (16.26)	23 (0.91)	22 (49)
	1 1/2	250 (9.84)	210 (8.27)	413 (16.26)	26 (1.02)	22 (49)
	2	315 (12.4)	229 (9.02)	507 (19.96)	35 (1.38)	37 (82)

CLASS 4500 - ASME B16.34

Unit: mm (inch)

Port	Valve Size	Handwheel Diameter	End to End	Center to Top (Open)	Dia. of Port Openings	Weight Kg (Lb)
Full	1/2	200 (7.87)	127 (5.00)	291 (11.46)	7 (0.28)	8 (18)
	3/4	230 (9.06)	155 (6.10)	333 (13.11)	11 (0.43)	13 (29)
	1	250 (9.84)	210 (8.27)	413 (16.26)	14 (0.55)	22 (49)
	1 1/4	315 (12.4)	229 (9.02)	507 (19.96)	22 (0.87)	37 (82)
	1 1/2	315 (12.4)	229 (9.02)	507 (19.96)	22 (0.87)	37 (82)
	2	315 (12.4)	250 (9.84)	510 (20.08)	25 (0.98)	48 (106)

Y-GLOBE VALVES - PRESSURE SEAL BONNET - FULL PORT

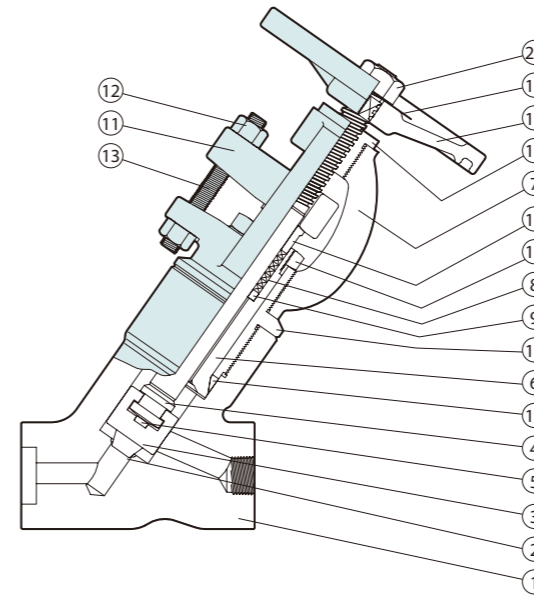

NO.	Parts	Material	A.S.T.M.
1	Body	Forged Steel	A105N
2	Seat	Integral Hardfaced Stellite 6	
3	Disc	Stellite 6 faced A276-410	
4	Stem	13Cr Stainless Steel	A276-410
5	Disc Pad	Stainless Steel	A276-316
6	Bonnet	Forged Steel	A105N
7	Yoke	Forged Steel	A105N
8	Gland Packing	Graphoil	
9	Packing Ring	Stainless Steel	A276-316
10	Gland	Stainless Steel	A276-316
11	Gland Flange	Forged Steel	A105
12	Gland Nut	Carbon Steel	A194-2H
13	Gland Bolt	Alloy Steel	A193-B7
14	Yoke Bush	High Tension Brass	
15	Gasket	Soft Iron	
16	Bonnet Guide	Forged Steel	A105N
17	Bonnet Nut	Carbon Steel	
18	Handwheel	Malleable Iron	A47
19	Name Plate	Aluminum	
20	Handwheel Nut	Carbon Steel	A194-2H

CLASS 1500 / 1690 - ASME B16.34

Unit: mm (inch)

Port	Valve Size	Handwheel Diameter	End to End	Center to Top (Open)	Dia. of Port Openings	Weight Kg (Lb)
Full	1/2	140 (5.51)	155 (6.10)	231 (9.10)	12 (0.47)	11 (24)
	3/4	140 (5.51)	155 (6.10)	274 (10.79)	16 (0.63)	11 (24)
	1	200 (7.87)	210 (8.27)	330 (12.99)	20 (0.79)	17 (38)
	1 1/2	230 (9.06)	229 (9.02)	401 (15.79)	32 (1.26)	29 (64)
	2	250 (9.84)	229 (9.02)	480 (18.90)	39 (1.54)	31 (68)

CLASS 2500 / 2680 - ASME B16.34

Unit: mm (inch)

Port	Valve Size	Handwheel Diameter	End to End	Center to Top (Open)	Dia. of Port Openings	Weight Kg (Lb)
Full	1/2	140 (5.51)	155 (6.10)	322 (12.68)	10 (0.39)	11 (24)
	3/4	200 (7.87)	210 (8.27)	390 (15.35)	13 (0.51)	18 (40)
	1	230 (9.06)	229 (9.02)	471 (18.54)	18 (0.71)	31 (68)
	1 1/2	250 (9.84)	235 (9.25)	511 (20.12)	26 (1.02)	43 (95)
	2	315 (12.4)	250 (9.84)	580 (22.84)	35 (1.38)	50 (110)

CLASS 4500 - ASME B16.34

Unit: mm (inch)

Port	Valve Size	Handwheel Diameter	End to End	Center to Top (Open)	Dia. of Port Openings	Weight Kg (Lb)
Full	1/2	140 (5.51)	155 (6.10)	312 (12.28)	7 (0.28)	11 (24)
	3/4	200 (7.87)	210 (8.27)	373 (14.69)	11 (0.43)	18 (40)
	1	230 (9.06)	229 (9.02)	444 (17.48)	14 (0.55)	31 (68)
	1 1/2	250 (9.84)	235 (9.25)	477 (18.78)	22 (0.87)	43 (95)
	2	315 (12.4)	250 (9.84)	546 (21.50)	25 (0.98)	50 (110)

Y-GLOBE VALVES - BONNETLESS - FULL PORT

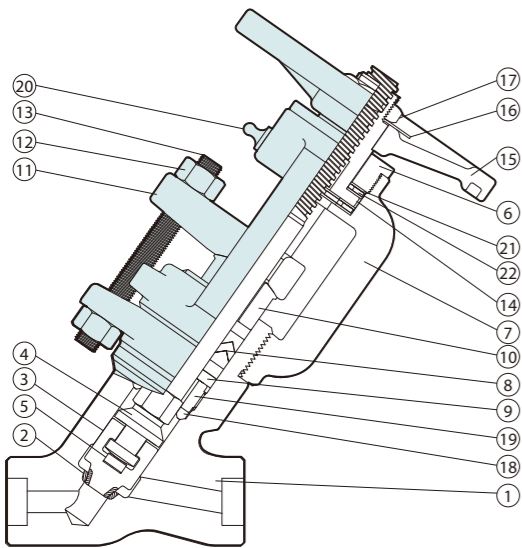

No.	Parts	Material	A.S.T.M.
1	Body	Forged Steel	A105N
2	Seat	Integral Hardfaced Stellite 6	
3	Disc	Stellite 6 faced A276-304/316	
4	Stem	13Cr Stainless steel	A276-410
5	Disc Pad	Stainless Steel	A276-316
6	Yoke Cap	13Cr Stainless steel	A276-410
7	Yoke	Forged Steel	A105N
8	Gland Packing	Graphoil	
9	Paking Ring	Stainless Steel	A276-316
10	Gland	Stainless Steel	A276-316
11	Gland Flange	Forged Steel	A105
12	Gland Nut	Carbon Steel	A194-2H
13	Gland Bolt	Alloy Steel	A193-B7
14	Yoke Sleeve	13Cr Stainless steel	A276-410
15	Handwheel	Malleable Iron	A47
16	Name Plate	Stainless Steel	A240-304
17	Handwheel Nut	Carbon Steel	A563A
18	Back Seat Ring	Stainless Steel	A276-316
19	Back Seat Bushing	13Cr Stainless steel	A276-410
20	Grease Nipple	Carbon Steel	
21	Needle Bearing Washer	-	
22	Needle Bearing	-	

CLASS 1500 / 1690 - ASME B 16.34

Unit: mm (inch)

Port	Valve Size	Handwheel Diameter	End to End	Center to Top (Open)	Dia. of Port Openings	Weight Kg (Lb)
Full	1/2	140 (5.51)	110 (4.33)	232 (9.13)	12 (0.43)	10 (22)
	3/4	140 (5.51)	127 (5.00)	250 (9.84)	16 (0.63)	11 (25)
	1	200 (7.87)	155 (6.10)	305 (12.01)	20 (0.79)	12 (27)
	1-1/2	230 (9.06)	210 (8.27)	408 (16.06)	32 (1.26)	36 (80)
	2	250 (9.84)	229 (9.02)	473 (18.62)	39 (1.54)	63 (139)

CLASS 2500 / 2680 - ASME B 16.34

Unit: mm (inch)

Port	Valve Size	Handwheel Diameter	End to End	Center to Top (Open)	Dia. of Port Openings	Weight Kg (Lb)
Full	1/2	140 (5.51)	110 (4.33)	234 (9.21)	10 (0.39)	10 (22)
	3/4	140 (5.51)	127 (5.00)	253 (9.96)	13 (0.51)	12 (27)
	1	200 (7.87)	155 (6.10)	309 (12.17)	18 (0.71)	25 (55)
	1-1/2	250 (9.84)	210 (8.27)	411 (16.18)	26 (1.02)	43 (95)
	2	315 (12.40)	229 (9.02)	478 (18.82)	35 (1.38)	65 (143)

CLASS 4500 - ASME B 16.34

Unit: mm (inch)

Port	Valve Size	Handwheel Diameter	End to End	Center to Top (Open)	Dia. of Port Openings	Weight Kg (Lb)
Full	1/2	140 (5.51)	127 (5.00)	258 (10.16)	11 (0.43)	20 (44)
	3/4	140 (5.51)	127 (5.00)	278 (10.94)	11 (0.43)	20 (44)
	1	200 (7.87)	165 (6.50)	324 (12.76)	14 (0.55)	28 (62)
	1-1/2	250 (9.84)	250 (9.84)	436 (17.17)	25 (0.98)	67 (148)
	2	250 (9.84)	250 (9.84)	492 (19.37)	25 (0.98)	67 (148)

LIFT CHECK VALVES - BOLTED / WELDED COVER - REDUCED / FULL PORT

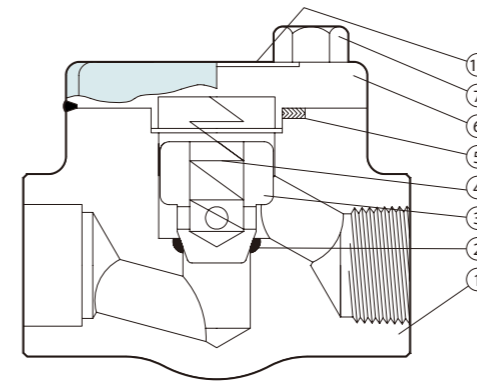

NO.	Parts	Material	A.S.T.M.
1	Body	Forged Steel	A105N
2	Seat	Integral Hardfaced Stellite 6	
3	Disc	13Cr Stainless Steel	A276-410
4	Spring	Stainless Steel	A276-316
5	Gasket	304 Spiral Wound Graphite	
6	Cover	Forged Steel	A105N
7	Cover Bolt	Alloy Steel	A193-B7
16	Name Plate	Aluminum	

* Ball type check valves also available

CLASS 600 / 800 - API 602 / ASME B16.34 / BS 5352

Unit: mm (inch)

Port	Valve Size	End to End	Center to Top	Dia. of Port Openings	Weight Kg (Lb)
Reduced	1/2	76 (2.99)	48 (1.89)	9.5 (0.37)	1.0 (2.2)
	3/4	86 (3.39)	54 (2.13)	12.7 (0.50)	1.3 (2.9)
	1	102 (4.02)	63 (2.48)	17.5 (0.69)	2.3 (5.1)
	11/4	152 (5.98)	81 (3.19)	22.5 (0.89)	5.0 (11.0)
	11/2	152 (5.98)	81 (3.19)	29.5 (1.16)	5.0 (11.0)
	2	172 (6.77)	105 (4.13)	35.0 (1.38)	7.0 (15.4)
Full	1/2	86 (3.39)	54 (2.13)	12.7 (0.50)	1.3 (2.9)
	3/4	102 (4.02)	63 (2.48)	17.5 (0.69)	2.3 (5.1)
	1	152 (5.98)	81 (3.19)	23.0 (0.91)	5.0 (11.0)
	11/4	172 (6.77)	105 (4.13)	29.5 (1.16)	7.0 (15.4)
	11/2	172 (6.77)	105 (4.13)	35.0 (1.38)	6.8 (15.0)
	2	218 (8.58)	147 (5.79)	45.5 (1.79)	10.6 (23.4)

CLASS 1500 - API 602 / ASME B16.34 / BS 5352

Unit: mm (inch)

Port	Valve Size	End to End	Center to Top	Dia. of Port Openings	Weight Kg (Lb)
Reduced	1/2	86 (3.39)	54 (2.13)	9.5 (0.37)	1.3 (2.9)
	3/4	102 (4.02)	63 (2.48)	12.7 (0.50)	2.3 (5.1)
	1	152 (5.98)	81 (3.19)	17.5 (0.69)	5.0 (11.0)
	11/4	172 (6.77)	105 (4.13)	22.5 (0.89)	7.0 (15.4)
	11/2	172 (6.77)	105 (4.13)	29.5 (1.16)	7.0 (15.4)
	2	210 (8.27)	128 (5.04)	35.0 (1.38)	9.1 (20.1)

LIFT CHECK VALVES – BOLTED / WELDED COVER – REDUCED PORT

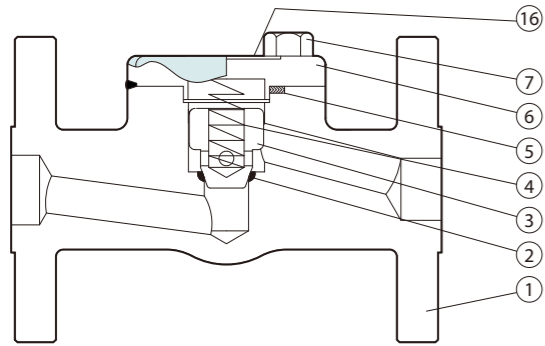

No.	Parts	Material	A.S.T.M.
1	Body	Forged Steel	A105N
2	Seat	Integral Hardfaced Stellite 6	
3	Disc	13Cr Stainless Steel	A276-410
4	Spring	Stainless Steel	A276-316
5	Gasket	304 Spiral Wound Graphite	
6	Cover	Forged Steel	A105N
7	Cover Bolt	Alloy Steel	A193-B7
16	Name Plate	Aluminum	

* Ball type check valves also available

CLASS 150 / 300 / 600 - API 602 / ASME B16.34 / BS 5352

Unit: mm (inch)

Port	Valve Size	Face to Face			Center to Top	Dia. of Port Openings	Weight Kg (Lb)		
		Class 150	Class 300	Class 600			Class 150	Class 300	Class 600
Reduced	1/2	108 (4.25)	152 (6.00)	165 (6.50)	48 (1.89)	9.5 (0.37)	1.7 (3.8)	2.2 (4.9)	2.5 (5.5)
	3/4	117 (4.62)	178 (7.00)	190 (7.50)	54 (2.13)	12.7 (0.50)	2.4 (5.3)	3.3 (7.3)	3.9 (8.6)
	1	127 (5.00)	203 (8.00)	216 (8.50)	63 (2.48)	17.5 (0.69)	3.8 (8.4)	5.1 (11.3)	5.7 (12.6)
	1 1/2	165 (6.50)	229 (9.00)	241 (9.50)	81 (3.19)	29.5 (1.16)	7.7 (17.0)	9.9 (21.8)	11.5 (25.4)
	2	203 (8.00)	267 (10.50)	292 (11.50)	105 (4.13)	35.0 (1.38)	11.4 (25.1)	13.0 (28.7)	13.8 (30.4)

CLASS 1500 - API 602 / ASME B16.34 / BS 5352

Unit: mm (inch)

Port	Valve Size	Face to Face	Center to Top	Dia. of Port Openings	Weight Kg (Lb)
Reduced	1/2	216 (8.50)	54 (2.13)	9.5 (0.37)	5.8 (12.8)
	3/4	229 (9.00)	63 (2.48)	12.7 (0.50)	7.8 (17.2)
	1	254 (10.00)	81 (3.19)	17.5 (0.69)	13.0 (28.7)
	1 1/2	305 (12.00)	105 (4.13)	29.5 (1.16)	20.7 (45.6)
	2	368 (14.25)	128 (5.04)	35.0 (1.38)	30.6 (67.5)

LIFT CHECK VALVES – BOLTED / WELDED COVER – FULL PORT

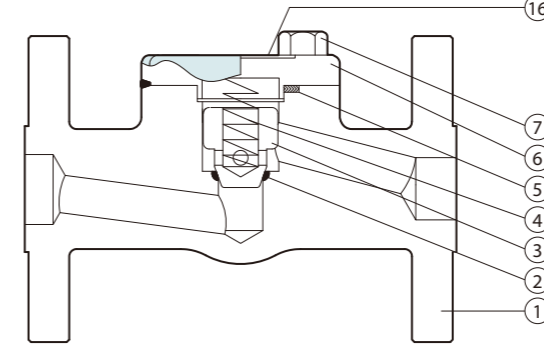

No.	Parts	Material	A.S.T.M.
1	Body	Forged Steel	A105N
2	Seat	Integral Hardfaced Stellite 6	
3	Disc	13Cr Stainless Steel	A276-410
4	Spring	Stainless Steel	A276-316
5	Gasket	304 Spiral Wound Graphite	
6	Cover	Forged Steel	A105N
7	Cover Bolt	Alloy Steel	A193-B7
16	Name Plate	Aluminum	

* Ball type check valves also available

CLASS 150 / 300 / 600 - API 602 / ASME B16.34 / BS 5352

Unit: mm (inch)

Port	Valve Size	Face to Face			Center to Top			Dia. of Port Openings	Weight Kg (Lb)		
		Class 150	Class 300	Class 600	Class 150	Class 300	Class 600		Class 150	Class 300	Class 600
Full	1/2	108 (4.25)	152 (6.00)	165 (6.50)	70 (2.76)	54 (2.13)	54 (2.13)	13.0 (0.51)	2.4 (5.3)	3.3 (7.3)	3.9 (8.6)
	3/4	117 (4.62)	178 (7.00)	190 (7.50)	63 (2.48)	63 (2.48)	63 (2.48)	17.5 (0.69)	3.8 (8.4)	5.1 (11.3)	5.7 (12.6)
	1	127 (5.00)	203 (8.00)	216 (8.50)	81 (3.19)	81 (3.19)	81 (3.19)	29.5 (1.16)	7.7 (17.0)	9.9 (21.8)	11.5 (25.4)
	1 1/2	165 (6.50)	229 (9.00)	241 (9.50)	105 (4.13)	105 (4.13)	105 (4.13)	35.0 (1.38)	11.4 (25.1)	13.0 (28.7)	13.8 (30.4)
	2	203 (8.00)	267 (10.5)	292 (11.50)	146 (5.75)	146 (5.75)	146 (5.75)	45.5 (1.79)	15.8 (34.8)	19.0 (41.9)	20.3 (44.8)

LIFT CHECK VALVES – RING JOINT COVER – REDUCED / FULL PORT

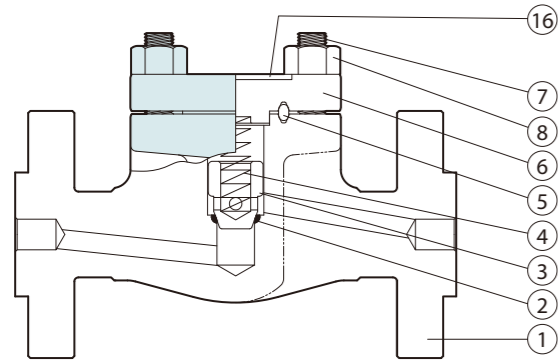

No.	Parts	Material	A.S.T.M.
1	Body	Forged Steel	A105N
2	Seat	Integral Hardfaced Stellite 6	
3	Disc	13Cr Stainless Steel	A217-CA15
4	Spring	Stainless Steel	A276-316
5	Gasket	Soft Iron	
6	Cover	Forged Steel	A105N
7	Cover Bolt	Alloy Steel	A193-B7
8	Cover Nut	Carbon Steel	A194-2H
16	Name Plate	Aluminum	

CLASS 1500 - API 602 / ASME B16.34

Unit: mm (inch)

Port	Valve Size	Face to Face	Center to Top	Dia. of Port Openings	Weight Kg (Lb)
Reduced	1/2	216 (8.50)	157 (6.18)	10 (0.39)	8 (18)
	3/4	229 (9.00)	180 (7.09)	15 (0.59)	13 (29)
	1	254 (10.00)	185 (7.28)	18 (0.71)	16 (35)
	1 1/2	305 (12.00)	210 (8.27)	28 (1.10)	29 (64)
	2	368 (14.25)	250 (9.84)	35 (1.38)	33 (73)

CLASS 2500 - ASME B16.34

Unit: mm (inch)

Port	Valve Size	Face to Face	Center to Top	Dia. of Port Openings	Weight Kg (Lb)
Full	1/2	264 (10.38)	180 (7.09)	10 (0.39)	17 (38)
	3/4	273 (10.75)	180 (7.09)	15 (0.59)	18 (40)
	1	308 (12.12)	200 (7.87)	18 (0.71)	23 (51)
	1 1/2	384 (15.12)	230 (9.06)	28 (1.10)	40 (88)
	2	451 (17.75)	250 (9.84)	35 (1.38)	54 (119)

LIFT CHECK VALVES – SEAL WELDED COVER – REDUCED / FULL PORT

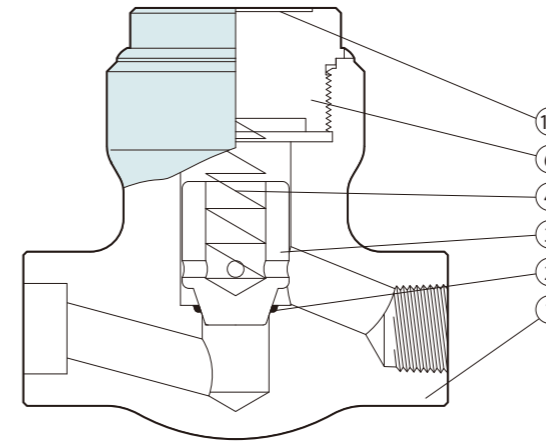

No.	Parts	Material	A.S.T.M.
1	Body	Forged Steel	A105N
2	Seat	Integral Hardfaced Stellite 6	
3	Disc	Stellite 6 faced A276-410	
4	Spring	Stainless Steel	A276-316
6	Cover	Forged Steel	A105N
16	Name Plate	Aluminum	

CLASS 1500 - ASME B16.34

Unit: mm (inch)

Port	Valve Size	End to End	Center to Top	Dia. of Port Openings	Weight Kg (Lb)
Reduced	1/2	110 (4.33)	81 (3.19)	9.5 (0.37)	2 (5)
	3/4	110 (4.33)	81 (3.19)	12 (0.47)	2 (5)
	1	127 (5.00)	96 (3.78)	16 (0.63)	3.5 (8)
	1 1/4	155 (6.10)	116 (4.57)	20 (0.79)	6 (13)
	1 1/2	155 (6.10)	116 (4.57)	27 (1.06)	6 (13)
2	210 (8.27)	147 (5.79)	32 (1.26)	13 (29)	
Full	1/2	110 (4.33)	81 (3.19)	12 (0.47)	2 (5)
	3/4	127 (5.00)	96 (3.78)	16 (0.63)	3.5 (8)
	1	155 (6.10)	116 (4.57)	20 (0.79)	6 (13)
	1 1/4	210 (8.27)	147 (5.79)	27 (1.06)	13 (29)
	1 1/2	210 (8.27)	147 (5.79)	32 (1.26)	13 (29)
2	229 (9.02)	178 (7.01)	39 (1.54)	19 (42)	

CLASS 2500 - ASME B16.34

Unit: mm (inch)

Port	Valve Size	End to End	Center to Top	Dia. of Port Openings	Weight Kg (Lb)
Full	1/2	110 (4.33)	86 (3.39)	10 (0.39)	3 (7)
	3/4	127 (5.00)	101 (3.98)	13 (0.51)	4 (9)
	1	155 (6.10)	121 (4.76)	18 (0.71)	8 (18)
	1 1/4	210 (8.27)	157 (6.18)	23 (0.91)	14 (31)
	1 1/2	210 (8.27)	157 (6.18)	26 (1.02)	14 (31)
	2	229 (9.02)	190 (7.48)	35 (1.38)	20 (44)

CLASS 4500 - ASME B16.34

Unit: mm (inch)

Port	Valve Size	End to End	Center to Top	Dia. of Port Openings	Weight Kg (Lb)
Full	1/2	127 (5.00)	101 (3.98)	7 (0.28)	4 (9)
	3/4	155 (6.10)	121 (4.76)	11 (0.43)	8 (18)
	1	210 (8.27)	157 (6.18)	14 (0.55)	14 (31)
	1 1/4	229 (9.02)	190 (7.48)	18 (0.71)	20 (44)
	1 1/2	229 (9.02)	190 (7.48)	22 (0.87)	20 (44)
	2	250 (9.84)	108 (8.19)	25 (0.98)	22 (49)

LIFT CHECK VALVES – PRESSURE SEAL COVER – FULL PORT

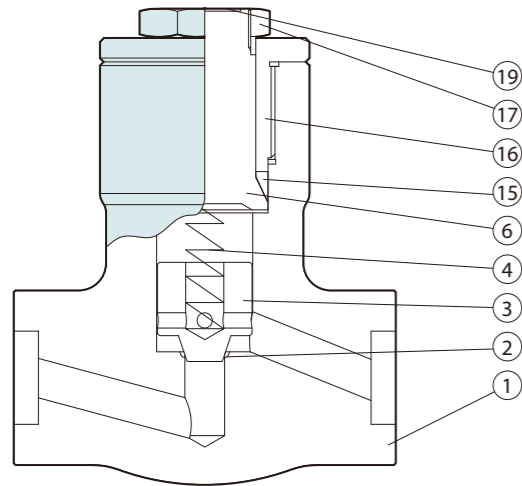

No.	Parts	Material	A.S.T.M.
1	Body	Forged Steel	A105N
2	Seat	Integral Hardfaced Stellite 6	
3	Disc	Stellite 6 faced A276-410	
4	Spring	Stainless Steel	A276-316
6	Bonnet	Forged Steel	A105N
15	Gasket	Soft Iron	
16	Bonnet Guide	Forged Steel	A105N
17	Bonnet Nut	Carbon Steel	A276-410
19	Name Plate	Aluminum	

CLASS 1500 - ASME B16.34

Unit: mm (inch)

Port	Valve Size	End to End	Center to Top	Dia. of Port Openings	Weight Kg (Lb)
Full	1/2	155 (6.10)	96 (3.78)	12 (0.47)	10 (22)
	3/4	155 (6.10)	116 (4.57)	16 (0.63)	10 (22)
	1	210 (8.27)	147 (5.79)	20 (0.79)	15 (33)
	1 1/2	229 (9.02)	178 (7.01)	32 (1.26)	22 (49)
	2	235 (9.25)	213 (8.39)	39 (1.54)	30 (66)

CLASS 2500 - ASME B16.34

Unit: mm (inch)

Port	Valve Size	End to End	Center to Top	Dia. of Port Openings	Weight Kg (Lb)
Full	1/2	155 (6.10)	116 (4.57)	10 (0.39)	10 (22)
	3/4	210 (8.27)	147 (5.79)	13 (0.51)	15 (33)
	1	229 (9.02)	178 (7.01)	18 (0.71)	24 (53)
	1 1/2	235 (9.25)	213 (8.39)	26 (1.02)	33 (73)
	2	235 (9.25)	213 (8.39)	35 (1.38)	32 (71)

CLASS 4500 - ASME B16.34

Unit: mm (inch)

Port	Valve Size	End to End	Center to Top	Dia. of Port Openings	Weight Kg (Lb)
Full	1/2	210 (8.27)	147 (5.79)	7 (0.28)	16 (35)
	3/4	210 (8.27)	178 (7.01)	11 (0.43)	16 (35)
	1	229 (9.02)	213 (8.39)	14 (0.55)	27 (60)
	1 1/2	235 (9.25)	239 (9.41)	22 (0.87)	34 (75)
	2	250 (9.84)	252 (9.92)	25 (0.98)	40 (88)

Y-CHECK VALVES – BOLTED / WELDED COVER – REDUCED / FULL PORT

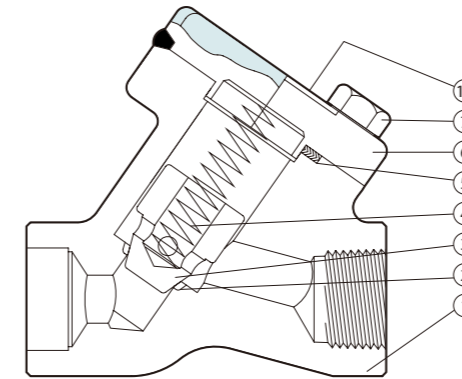

No.	Parts	Material	A.S.T.M.
1	Body	Forged Steel	A105N
2	Seat	Integral Hardfaced Stellite 6	
3	Disc	13Cr Stainless Steel	A276-410
4	Spring	Stainless Steel	A276-316
5	Gasket	304 Spiral Wound Graphite	
6	Cover	Forged Steel	A105N
7	Cover Bolt	Alloy Steel	A193-B7
16	Name Plate	Aluminum	

* Ball type check valves also available

CLASS 600 / 800 - API 602 / ASME B16.34 / BS 5352

Unit: mm (inch)

Port	Valve Size	End to End	Center to Top	Dia. of Port Openings	Weight Kg (Lb)
Reduced	1/2	84 (3.31)	73 (2.87)	9.5 (0.37)	1.2 (3)
	3/4	95 (3.74)	85 (3.35)	12.7 (0.50)	1.6 (4)
	1	106 (4.17)	88 (3.47)	17.5 (0.69)	2.5 (6)
	1 1/4	137 (5.39)	121 (4.76)	22.5 (0.89)	5.5 (12)
	1 1/2	137 (5.39)	121 (4.76)	29.5 (1.16)	5.4 (12)
2	172 (6.77)	174 (6.85)	35.0 (1.38)	7.8 (17)	
Full	1/2	95 (3.74)	85 (3.35)	12.7 (0.50)	1.3 (3)
	3/4	106 (4.17)	88 (3.47)	17.5 (0.69)	2.3 (5)
	1	137 (5.39)	121 (4.76)	23.0 (0.91)	5.0 (11)
	1 1/4	172 (6.77)	174 (6.85)	29.5 (1.16)	7.0 (15.5)
	1 1/2	172 (6.77)	174 (6.85)	35.0 (1.38)	6.8 (15)
2	200 (7.87)	208 (8.19)	45.5 (1.79)	10.6 (23)	

Y-CHECK VALVES – SEAL WELDED COVER – REDUCED / FULL PORT

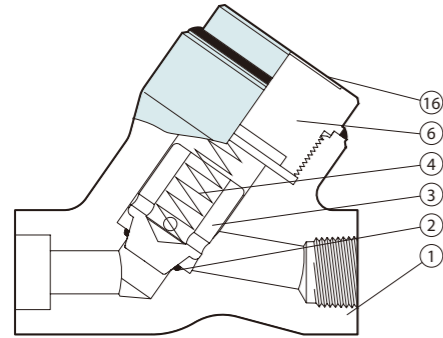

No.	Parts	Material	A.S.T.M.
1	Body	Forged Steel	A105N
2	Seat	Integral Hardfaced Stellite 6	
3	Disc	Stellite 6 faced A276-410	
4	Spring	Stainless Steel	A276-316
6	Cover	Forged Steel	A105N
16	Name Plate	Aluminum	

CLASS 1500 / 1690 - ASME B16.34

Unit: mm (inch)

Port	Valve Size	End to End	Center to Top	Dia. of Port Openings	Weight Kg (Lb)
Reduced	1/2	110 (4.33)	91 (3.58)	9.5 (0.37)	2 (5)
	3/4	110 (4.33)	91 (3.58)	12 (0.47)	2 (5)
	1	127 (5.00)	105 (4.13)	16 (0.63)	3.5 (8)
	1 1/4	155 (6.10)	127 (5.00)	20 (0.79)	6 (13)
	1 1/2	155 (6.10)	127 (5.00)	27 (1.06)	6 (13)
2	210 (8.27)	166 (6.54)	32 (1.26)	13 (29)	
Full	1/2	110 (4.33)	86 (3.39)	12 (0.47)	2 (5)
	3/4	127 (5.00)	99 (3.90)	16 (0.63)	3.5 (8)
	1	155 (6.10)	122 (4.80)	20 (0.79)	6 (13)
	1 1/4	210 (8.27)	156 (6.14)	27 (1.06)	13 (29)
	1 1/2	210 (8.27)	156 (6.14)	32 (1.26)	13 (29)
2	229 (9.02)	186 (7.32)	39 (1.54)	19 (42)	

CLASS 2500 / 2680 - ASME B16.34

Unit: mm (inch)

Port	Valve Size	End to End	Center to Top	Dia. of Port Openings	Weight Kg (Lb)
Full	1/2	110 (4.33)	91 (3.58)	10 (0.39)	3 (7)
	3/4	127 (5.00)	105 (4.13)	13 (0.51)	4 (9)
	1	155 (6.10)	127 (5.00)	18 (0.71)	8 (18)
	1 1/4	210 (8.27)	166 (6.54)	23 (0.91)	14 (31)
	1 1/2	210 (8.27)	166 (6.54)	26 (1.02)	14 (31)
	2	229 (9.02)	198 (7.80)	35 (1.38)	20 (44)

CLASS 4500 - ASME B16.34

Unit: mm (inch)

Port	Valve Size	End to End	Center to Top	Dia. of Port Openings	Weight Kg (Lb)
Full	1/2	127 (5.00)	105 (4.13)	7 (0.28)	4 (9)
	3/4	155 (6.10)	127 (5.00)	11 (0.43)	8 (18)
	1	210 (8.27)	166 (6.54)	14 (0.55)	14 (31)
	1 1/4	229 (9.02)	198 (7.80)	18 (0.71)	20 (44)
	1 1/2	229 (9.02)	198 (7.80)	22 (0.87)	20 (44)
	2	250 (9.84)	210 (8.27)	25 (0.98)	22 (49)

Y-CHECK VALVES – PRESSURE SEAL COVER – FULL PORT

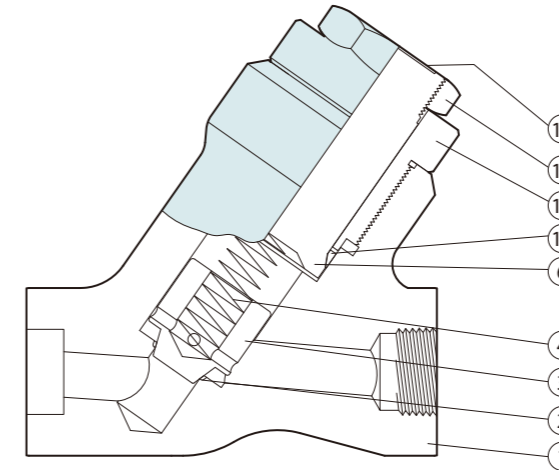

No.	Parts	Material	A.S.T.M.
1	Body	Forged Steel	A105N
2	Seat	Integral Hardfaced Stellite 6	
3	Disc	Stellite 6 faced A276-410	
4	Spring	Stainless Steel	A276-316
6	Bonnet	Forged Steel	A105N
15	Gasket	Soft Iron	
16	Bonnet Guide	Forged Steel	A105N
17	Bonnet Nut	Carbon Steel	A276-410
19	Name Plate	Aluminum	

CLASS 1500 / 1690 - ASME B16.34

Unit: mm (inch)

Port	Valve Size	End to End	Center to Top	Dia. of Port Openings	Weight Kg (Lb)
Full	1/2	155 (6.10)	101 (3.98)	12 (0.47)	10 (22)
	3/4	155 (6.10)	119 (4.69)	16 (0.63)	10 (22)
	1	210 (8.27)	153 (6.02)	20 (0.79)	15 (33)
	1 1/2	229 (9.02)	187 (7.36)	32 (1.26)	22 (49)
	2	229 (9.02)	187 (7.36)	39 (1.54)	30 (66)

CLASS 2500 / 2680 - ASME B16.34

Unit: mm (inch)

Port	Valve Size	End to End	Center to Top	Dia. of Port Openings	Weight Kg (Lb)
Full	1/2	155 (6.10)	119 (4.69)	10 (0.39)	10 (22)
	3/4	210 (8.27)	153 (6.02)	13 (0.51)	15 (33)
	1	229 (9.02)	187 (7.36)	18 (0.71)	24 (53)
	1 1/2	235 (9.25)	221 (8.70)	26 (1.02)	33 (73)
	2	250 (9.84)	252 (9.92)	35 (1.38)	32 (71)

CLASS 4500 - ASME B16.34

Unit: mm (inch)

Port	Valve Size	End to End	Center to Top	Dia. of Port Openings	Weight Kg (Lb)
Full	1/2	155 (6.10)	119 (4.69)	7 (0.28)	10 (22)
	3/4	210 (8.27)	153 (6.02)	11 (0.43)	16 (35)
	1	229 (9.02)	187 (7.36)	14 (0.55)	27 (60)
	1 1/2	235 (9.25)	221 (8.70)	22 (0.87)	34 (75)
	2	250 (9.84)	252 (9.92)	25 (0.98)	40 (88)

Forged Steel Swing Check Valves

Forged Steel Swing Check Valves

SWING CHECK VALVES – BOLTED / WELDED COVER – REDUCED / FULL PORT

SWING CHECK VALVES – BOLTED / WELDED COVER – REDUCED PORT

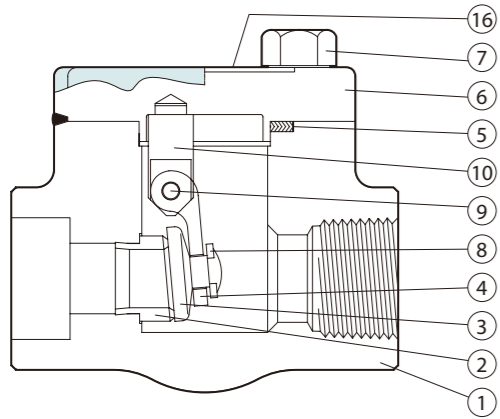

No.	Parts	Material	A.S.T.M.
1	Body	Forged Steel	A105N
2	Seat Ring	Stellite 6 faced A276-410	
3	Disc	Stellite 6 faced A276-316	
4	Hinge	Stainless Steel	A351-CF8M
5	Gasket	304 Spiral Wound Graphite	
6	Cover	Forged Steel	A105N
7	Cover Bolt	Alloy Steel	A193-B7
8	Ret. Washer	Stainless Steel	A276-316
9	Support Pin	Stainless Steel	A276-316
10	Support	Stainless Steel	A276-316
16	Name Plate	Aluminum	

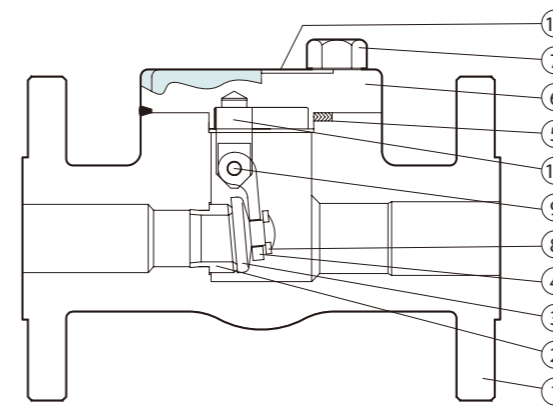

No.	Parts	Material	A.S.T.M.
1	Body	Forged Steel	A105N
2	Seat Ring	Stellite 6 faced A276-410	
3	Disc	Stellite 6 faced A276-316	
4	Hinge	Stainless Steel	A351-CF8M
5	Gasket	304 Spiral Wound Graphite	
6	Cover	Forged Steel	A105N
7	Cover Bolt	Alloy Steel	A193-B7
8	Ret. Washer	Stainless Steel	A276-316
9	Support Pin	Stainless Steel	A276-316
10	Support	Stainless Steel	A276-316
16	Name Plate	Aluminum	

CLASS 600 / 800 - API 602 / ASME B16.34 / BS 5352

Unit: mm (inch)

Port	Valve Size	End to End	Center to Top	Dia. of Port Openings	Weight Kg (Lb)
	3/4	86 (3.39)	54 (2.13)	13.0 (0.51)	1.1 (2.4)
	1	102 (4.02)	63 (2.48)	18.0 (0.71)	2.0 (4.4)
	1 1/4	117 (4.61)	89 (3.50)	31.0 (1.22)	4.4 (9.7)
	1 1/2	117 (4.61)	89 (3.50)	31.0 (1.22)	4.4 (9.7)
	2	133 (5.24)	105 (4.13)	37.0 (1.46)	6.2 (13.7)
Full	1/2	86 (3.39)	54 (2.13)	13.0 (0.51)	1.1 (2.4)
	3/4	102 (4.02)	63 (2.48)	18.0 (0.71)	2.0 (4.4)
	1	117 (4.61)	89 (3.50)	23.0 (0.91)	4.4 (9.7)
	1 1/4	133 (5.24)	105 (4.13)	37.0 (1.46)	6.2 (13.7)
	1 1/2	133 (5.24)	105 (4.13)	37.0 (1.46)	6.2 (13.7)
	2	218 (8.58)	147 (5.79)	50.8 (2.00)	9.1 (20.1)

CLASS 1500 - API 602 / ASME B16.34 / BS 5352

Unit: mm (inch)

Port	Valve Size	End to End	Center to Top	Dia. of Port Openings	Weight Kg (Lb)
	3/4	102 (4.02)	63 (2.48)	13.0 (0.51)	2.0 (4.4)
	1	117 (4.61)	89 (3.50)	18.0 (0.71)	4.4 (9.7)
	1 1/4	133 (5.24)	105 (4.13)	31.0 (1.22)	6.2 (13.7)
	1 1/2	133 (5.24)	105 (4.13)	31.0 (1.22)	6.2 (13.7)
	2	210 (8.27)	147 (5.79)	37.0 (1.46)	9.1 (20.1)

CLASS 150 / 300 / 600 - API 602 / ASME B16.34 / BS 5352

Unit: mm (inch)

Port	Valve Size	Face to Face			Center to Top	Dia. of Port Openings	Weight Kg (Lb)		
		Class 150	Class 300	Class 600			Class 150	Class 300	Class 600
Reduced	1/2	108 (4.25)	140 (5.50)	165 (6.50)	48 (1.89)	9.8 (0.39)	1.3 (2.9)	1.7 (3.8)	2.5 (5.5)
	3/4	117 (4.62)	152 (6.00)	190 (7.50)	54 (2.13)	13.0 (0.51)	1.9 (4.2)	2.8 (6.2)	3.9 (8.6)
	1	127 (5.00)	216 (8.50)	216 (8.50)	63 (2.48)	18.0 (0.71)	3.1 (6.8)	4.6 (10.1)	5.7 (12.6)
	1 1/2	165 (6.50)	241 (9.50)	241 (9.50)	89 (3.50)	31.0 (1.22)	6.4 (14.1)	9.1 (20.1)	11.5 (25.4)
	2	203 (8.00)	267 (10.50)	292 (11.50)	105 (4.13)	37.0 (1.46)	9.1 (20.1)	11.8 (26.0)	13.8 (30.4)

CLASS 1500 - API 602 / ASME B16.34 / BS 5352

Unit: mm (inch)

Port	Valve Size	Face to Face	Center to Top	Dia. of Port Openings	Weight Kg (Lb)
	3/4	229 (9.00)	63 (2.48)	13.0 (0.51)	7.9 (17.4)
	1	254 (10.00)	89 (3.50)	18.0 (0.71)	12.7 (28.0)
	1 1/2	305 (12.00)	105 (4.13)	31.0 (1.22)	17.6 (38.8)
	2	368 (14.25)	128 (5.04)	37.0 (1.46)	23.2 (51.2)

A105, A350-LF2**STANDARD CLASS**

NOTE: Permissible, but not recommended for prolonged usage above 800°F (425°C).

Working Pressure by Classes, psig

CLASS		150	300	600	800	900	1,500	1,690	2,500	2,680	4,500
Shell Test, psig		450	1,125	2,225	2,975	3,350	5,575	6,275	9,275	9,925	16,675
Seat Test, psig		325	825	1,650	2,175	2,450	4,100	4,600	6,800	7,300	12,225
-20 to 100°F	-29 to 38°C	285	740	1,480	1,975	2,220	3,705	4,175	6,170	6,615	11,110
200	93.5	260	680	1,360	1,810	2,035	3,395	3,825	5,655	6,065	10,185
300	149.0	230	655	1,310	1,745	1,965	3,270	3,685	5,845	5,845	9,815
400	204.5	200	635	1,265	1,690	1,900	3,170	3,570	5,280	5,660	9,505
500	260.0	170	605	1,205	1,610	1,810	3,015	3,395	5,025	5,385	9,040
600	315.5	140	570	1,135	1,515	1,705	2,840	3,195	4,730	5,070	8,515
650	343.5	125	550	1,100	1,465	1,650	2,745	3,095	4,575	4,905	8,240
700	371.0	110	530	1,060	1,415	1,590	2,665	2,995	4,425	4,745	7,960
750	399.0	95	505	1,015	1,350	1,520	2,535	2,855	4,230	4,535	7,610
800	426.5	80	410	825	1,100	1,235	2,055	2,315	3,430	3,675	6,170
850	454.5	65	320	640	850	955	1,595	1,795	2,655	2,845	4,785
900	482.0	50	230	460	615	690	1,150	1,295	1,915	2,055	3,455
950	510.0	35	135	275	365	410	685	775	1,145	1,225	2,055
1000	538.0	20	85	170	225	255	430	485	715	765	1,285

A182-F11 CL.2**STANDARD CLASS**

NOTE: Permissible, but not recommended for prolonged usage above 1100°F (595°C).

Working Pressure by Classes, psig

CLASS		150	300	600	800	900	1,500	1,690	2,500	2,680	4,500
Shell Test, psig		450	1,125	2,250	3,000	3,375	5,625	6,350	9,375	10,050	16,875
Seat Test, psig		325	825	1,650	2,200	2,475	4,125	4,650	6,875	7,375	12,375
-20 to 100°F	-29 to 38°C	290	750	1,500	2,000	2,250	3,750	4,225	6,250	6,700	11,250
200	93.5	260	750	1,500	2,000	2,250	3,750	4,225	6,250	6,700	11,250
300	149.0	230	720	1,445	1,925	2,165	3,610	4,065	6,015	6,450	10,830
400	204.5	200	695	1,385	1,850	2,080	3,465	3,905	5,775	6,190	10,400
500	260.0	170	665	1,330	1,775	1,995	3,325	3,745	5,540	5,940	9,965
600	315.5	140	605	1,210	1,615	1,815	3,025	3,410	5,040	5,405	9,070
650	343.5	125	590	1,175	1,570	1,765	2,940	3,315	4,905	5,260	8,825
700	371.0	110	570	1,135	1,515	1,705	2,840	3,200	4,730	5,070	8,515
750	399.0	95	530	1,065	1,420	1,595	2,660	2,995	4,430	4,750	7,970
800	426.5	80	510	1,015	1,355	1,525	2,540	2,860	4,230	4,535	7,610
850	454.5	65	485	975	1,300	1,460	2,435	2,745	4,060	4,350	7,305
900	482.0	50	450	900	1,200	1,350	2,245	2,530	3,745	4,015	6,740
950	510.0	35	320	640	850	955	1,595	1,795	2,655	2,845	4,785
1000	538.0	20	215	430	575	650	1,080	1,215	1,800	1,930	3,240
1050	565.5	20(*)	145	290	385	430	720	810	1,200	1,285	2,160
1100	593.5	20(*)	95	190	255	290	480	540	800	860	1,440
1150	621.0	20(*)	65	130	175	195	325	385	545	585	975
1200	649.0	15(*)	40	80	110	125	205	235	345	365	615

* For welding end valves only. Flanged end ratings terminate at 1000°F (538°C).

A182-F22 CL.3**STANDARD CLASS**

NOTE: Permissible, but not recommended for prolonged usage above 1100°F (595°C).

Working Pressure by Classes, psig

CLASS		150	300	600	800	900	1,500	1,690	2,500	2,680	4,500
Shell Test, psig		450	1,125	2,225	3,000	3,375	5,625	6,350	9,375	10,050	16,875
Seat Test, psig		325	825	1,650	2,200	2,475	4,125	4,650	6,875	7,375	12,375
-20 to 100°F	-29 to 38°C	290	750	1,500	2,000	2,250	3,750	4,225	6,250	6,700	11,250
200	93.5	260	750	1,500	2,000	2,250	3,750	4,225	6,250	6,700	11,250
300	149.0	230	730	1,455	1,940	2,185	3,640	4,100	6,070	6,505	10,925
400	204.5	200	705	1,410	1,880	2,115	3,530	3,975	5,880	6,305	10,585
500	260.0	170	665	1,330	1,775	1,995	3,325	3,745	5,540	5,940	9,965
600	315.5	140	605	1,210	1,615	1,815	3,025	3,410	5,040	5,405	9,070
650	343.5	125	590	1,175	1,570	1,765	2,940	3,315	4,905	5,260	8,825
700	371.0	110	570	1,135	1,515	1,705	2,840	3,200	4,730	5,070	8,515
750	399.0	95	530	1,065	1,420	1,595	2,660	2,995	4,430	4,750	7,970
800	426.5	80	510	1,015	1,355	1,525	2,540	2,860	4,230	4,535	7,610
850	454.5	65	485	975	1,300	1,460	2,435	2,745	4,060	4,350	7,305
900	482.0	50	450	900	1,200	1,350	2,245	2,530	3,745	4,015	6,740
950	510.0	35	385	755	1,025	1,160	1,930	2,175	3,220	3,455	5,795
1000	538.0	20	265	535	710	800	1,335	1,695	3,230	3,300	4,010
1050	565.5	20(*)	175	350	465	525	875	985	1,455	1,560	2,625
1100	593.5	20(*)	110	220	295	330	550	620	915	980	1,645
1150	621.0	20(*)	70	135	180	205	345	390	570	610	1,030
1200	649.0	15(*)	40	80	110	125	205	230	345	370	615

* For welding end valves only. Flanged end ratings terminate at 1000°F (538°C).

A182-F5**STANDARD CLASS**

Working Pressure by Classes, psig

CLASS		150	300	600	800	900	1,500	1,690	2,500	2,680	4,500
Shell Test, psig		450	1,125	2,225	3,000	3,375	5,625	6,350	9,375	10,050	16,875
Seat Test, psig		325	825	1,650	2,200	2,475	4,125	4,650	6,875	7,375	12,375
-20 to 100°F	-29 to 38°C	290	750	1,500	2,000	2,250	3,750	4,225	6,250	6,700	11,250
200	93.5	260	735	1,470	1,965	2,210	3,680	4,145	6,135	6,575	11,040
300	149.0	230	700	1,400	1,865	2,100	3,495	3,935	5,830	6,245	10,490
400	204.5	200	670	1,335	1,780	2,005	3,345	3,765	5,570	5,975	10,030
500	260.0	170	645	1,290	1,725	1,940	3,230	3,635	5,385	5,775	9,690
600	315.5	140	605	1,210	1,615	1,815	3,025	3,410	5,040	5,405	9,070
650	343.5	125	590	1,175	1,570	1,765	2,940	3,315	4,905	5,260	8,825
700	371.0	110	570	1,135	1,515	1,705	2,840	3,200	4,730	5,070	8,515
750	399.0	95	530	1,065	1,420	1,595	2,660	2,995	4,430	4,745	7,970
800	426.5	80	510	1,015	1,355	1,525	2,540	2,860	4,230	4,535	7,610
850	454.5	65	485	975	1,300	1,460	2,435	2,745	4,060	4,355	7,305
900	482.0	50	375	745	995	1,120	1,870	2,105	3,115	3,335	5,605
950	510.0	35	275	550	735	825	1,370	1,545	2,285	2,450	4,115
1000	538.0	20	200	400	530	595	995	1,120	1,655	1,775	2,985
1050	565.5	20(*)	145	290	385	430	720	810	1,200	1,285	2,160
1100	593.5	20(*)	95	190	255	290	480	540	800	855	1,440
1150	621.0	20(*)	60	125	165	185	310	350	515	550	925
1200	649.0	15(*)	35	70	95	105	170	190	285	305	515

* For welding end valves only. Flanged end ratings terminate at 1000°F (538°C).

A182-F9

STANDARD CLASS

Working Pressure by Classes, psig

CLASS		150	300	600	800	900	1,500	1,690	2,500	2,680	4,500
Shell Test, psig		450	1,125	2,225	3,000	3,375	5,625	6,350	9,375	10,050	16,875
Seat Test, psig		325	825	1,650	2,200	2,475	4,125	4,650	6,875	7,375	12,375
-20 to 100°F	-29 to 38°C	290	750	1,500	2,000	2,250	3,750	4,225	6,250	6,700	11,250
200	93.5	260	750	1,500	2,000	2,250	3,750	4,225	6,250	6,700	11,250
300	149.0	230	730	1,455	1,940	2,185	3,640	4,100	6,070	6,505	10,925
400	204.5	200	705	1,410	1,880	2,115	3,530	3,975	5,880	6,305	10,585
500	260.0	170	665	1,330	1,775	1,995	3,325	3,745	5,540	5,940	9,965
600	315.5	140	605	1,210	1,615	1,815	3,025	3,410	5,040	5,405	9,070
650	343.5	125	590	1,175	1,570	1,765	2,940	3,315	4,905	5,260	8,825
700	371.0	110	570	1,135	1,515	1,705	2,840	3,200	4,730	5,070	8,515
750	399.0	95	530	1,065	1,420	1,595	2,660	2,995	4,430	4,750	7,970
800	426.5	80	510	1,015	1,355	1,525	2,540	2,860	4,230	4,535	7,610
850	454.5	65	485	975	1,300	1,460	2,435	2,745	4,060	4,350	7,305
900	482.0	50	450	900	1,200	1,350	2,245	2,530	3,745	4,015	6,740
950	510.0	35	375	755	1,005	1,130	1,885	2,125	3,145	3,370	5,655
1000	538.0	20	255	505	675	760	1,270	1,430	2,115	2,265	3,805
1050	565.5	20(*)	170	345	460	515	855	965	1,430	1,535	2,570
1100	593.5	20(*)	115	225	300	340	565	635	945	1,015	1,695
1150	621.0	20(*)	75	150	200	225	375	425	630	675	1,130
1200	649.0	20(*)	50	105	140	155	255	290	430	460	770

* For welding end valves only. Flanged end ratings terminate at 1000°F (538°C).

A182-F91

STANDARD CLASS

Working Pressure by Classes, psig

CLASS		150	300	600	800	900	1,500	1,690	2,500	2,680	4,500
Shell Test, psig		450	1,125	2,225	3,000	3,375	5,625	6,350	9,375	10,050	16,875
Seat Test, psig		325	825	1,650	2,200	2,475	4,125	4,650	6,875	7,375	12,375
-20 to 100°F	-29 to 38°C	290	750	1,500	2,000	2,250	3,750	4,225	6,250	6,700	11,250
200	93.5	260	750	1,500	2,000	2,250	3,750	4,225	6,250	6,700	11,250
300	149.0	230	730	1,455	1,945	2,185	3,640	4,100	6,070	6,505	10,925
400	204.5	200	705	1,410	1,880	2,115	3,530	3,975	5,880	6,305	10,585
500	260.0	170	665	1,330	1,775	1,995	3,325	3,745	5,540	5,940	9,965
600	315.5	140	605	1,210	1,615	1,815	3,025	3,410	5,040	5,405	9,070
650	343.5	125	590	1,175	1,570	1,765	2,940	3,315	4,905	5,260	8,825
700	371.0	110	570	1,135	1,515	1,705	2,840	3,200	4,730	5,070	8,515
750	399.0	95	530	1,065	1,420	1,595	2,660	2,995	4,430	4,750	7,970
800	426.5	80	510	1,015	1,355	1,525	2,540	2,860	4,230	4,535	7,610
850	454.5	65	485	975	1,300	1,460	2,435	2,745	4,060	4,350	7,305
900	482.0	50	450	900	1,200	1,350	2,245	2,530	3,745	4,015	6,740
950	510.0	35	385	775	1,035	1,160	1,930	2,175	3,220	3,450	5,795
1000	538.0	20	365	725	970	1,090	1,820	2,050	3,030	3,250	5,450
1050	565.5	20(*)	360	720	960	1,080	1,800	2,030	3,000	3,215	5,400
1100	593.5	20(*)	300	605	805	905	1,510	1,700	2,515	2,695	4,525
1150	621.0	20(*)	225	445	595	670	1,115	1,255	1,855	1,990	3,345
1200	649.0	20(*)	145	290	385	430	720	810	1,200	1,285	2,160

* For welding end valves only. Flanged end ratings terminate at 1000°F (538°C).

A182-F304

STANDARD CLASS

NOTE: At temperatures over 1000°F (538°C), use only when the carbon content is 0.04% or higher.

Working Pressure by Classes, psig

CLASS		150	300	600	800	900	1,500	1,690	2,500	2,680	4,500
Seat Test, psig		425	1,100	2,175	2,900	3,250	5,400	6,100	9,000	9,650	16,200
Shell Test, psig		325	800	1,600	2,125	2,400	3,975	4,475	6,600	7,075	11,900
-20 to 100°F	-29 to 38°C	275	720	1,440	1,920	2,160	3,600	4,056	6,000	6,432	10,800
200	93.5	230	600	1,200	1,600	1,800	3,000	3,380	5,000	5,360	9,000
300	149.0	205	540	1,075	1,435	1,615	3,690	3,030	4,480	4,805	8,065
400	204.5	190	495	995	1,325	1,490	2,485	2,800	4,140	4,440	7,450
500	260.0	170	465	930	1,240	1,395	2,330	2,625	3,880	4,160	6,985
600	315.5	140	440	885	1,180	1,325	2,210	2,480	3,680	3,945	6,625
650	343.5	125	430	865	1,150	1,295	2,160	2,435	3,600	3,855	6,480
700	371.0	110	420	845	1,125	1,265	2,110	2,375	3,520	3,775	6,335
750	399.0	95	415	825	1,100	1,240	2,065	2,325	3,440	3,685	6,190
800	426.5	80	405	810	1,080	1,215	2,030	2,285	3,380	3,625	6,085
850	454.5	65	395	790	1,055	1,190	1,980	2,230	3,300	3,540	5,940
900	482.0	50	390	780	1,035	1,165	1,945	2,190	3,240	3,475	5,830
950	510.0	35	380	765	1,020	1,145	1,910	2,150	3,180	3,410	5,725
1000	538.0	20	355	710	945	1,065	1,770	1,995	2,950	3,165	5,315
1050	565.5	20(*)	325	650	865	975	1,630	1,835	2,715	2,915	4,885
1100	593.5	20(*)	255	515	685	770	1,285	1,450	2,145	2,300	3,855
1150	621.0	20(*)	205	410	545	615	1,030	1,160	1,715	1,835	3,085
1200	649.0	20(*)	165	330	440	495	825	925	1,370	1,465	2,470
1250	676.5	20(*)	135	265	355	400	670	755	1,115	1,195	2,005
1300	704.5	20(*)	115	225	300	340	565	635	945	1,015	1,695
1350	732.0	20(*)	95	185	250	280	465	525	770	825	1,390
1400	760.0	20(*)	75	150	200	225	380	425	630	675	1,130
1450	788.0	20(*)	60	115	155	175	290	325	485	520	875
1500	815.5	15(*)	40	85	110	125	205	235	345	365	620

* For welding end valves only. Flanged end ratings terminate at 1000°F (538°C).

A182-F316

STANDARD CLASS

NOTE: At temperatures over 1000°F (538°C), use only when the carbon content is 0.04% or higher.

Working Pressure by Classes, psig

CLASS		150	300	600	800	900	1,500	1,690	2,500	2,680	4,500
Shell Test, psig		425	1,100	2,175	2,900	3,250	5,400	6,100	9,000	9,650	16,200
Seat Test, psig		325	800	1,600	2,125	2,400	3,975	4,475	6,600	7,075	11,900
-20 to 100°F	-29 to 38°C	275	720	1,440	1,920	2,160	3,600	4,055	6,000	6,430	10,800
200	93.5	235	620	1,240	1,655	1,860	3,095	3,485	5,160	5,530	9,290
300	149.0	215	560	1,120	1,495	1,680	2,795	3,150	4,660	4,995	8,390
400	204.5	195	515	1,025	1,370	1,540	2,570	2,895	4,280	4,590	7,705
500	260.0	170	480	955	1,275	1,435	2,390	2,690	3,980	4,265	7,165
600	315.5	140	450	900	1,205	1,355	2,255	2,540	3,760	4,030	6,770
650	343.5	125	440	885	1,180	1,325	2,210	2,485	3,680	3,945	6,625
700	371.0	110	435	870	1,160	1,305	2,170	2,445	3,620	3,880	6,515
750	399.0	95	425	855	1,140	1,280	2,135	2,405	3,560	3,815	6,410

A182-F304L, A182-F316L

STANDARD CLASS

NOTE: Not to be used over 800°F (425°C).

Working Pressure by Classes, psig

CLASS		150	300	600	800	900	1,500	1,690	2,500	2,680	4,500
Shell Test, psig		350	900	1,800	2,400	2,700	4,500	5,075	7,500	8,050	13,500
Seat Test, psig		275	675	1,325	1,775	2,000	3,300	3,725	5,500	5,900	9,900
-20 to 100 °F	-29 to 38 °C	230	600	1,200	1,600	1,800	3,000	3,380	5,000	5,360	9,000
200	93.5	195	510	1,020	1,365	1,535	2,555	2,875	4,260	4,565	7,670
300	149.0	175	455	910	1,215	1,370	2,280	2,565	3,800	4,075	6,840
400	204.5	160	420	840	1,120	1,260	2,100	2,365	3,500	3,755	6,300
500	260.0	150	395	785	1,050	1,180	1,970	2,215	3,280	3,515	5,905
600	315.5	140	370	745	990	1,115	1,860	2,095	3,100	3,325	5,580
650	343.5	125	365	730	975	1,095	1,825	2,055	3,040	3,255	5,470
700	371.0	110	360	720	960	1,080	1,800	2,025	3,000	3,215	5,400
750	399.0	110	355	705	940	1,060	1,765	1,985	2,940	3,155	5,290
800	426.5	80	345	690	920	1,035	1,730	1,945	2,880	3,085	5,185
850	454.5	65	340	675	900	1,015	1,690	1,905	2,820	3,025	5,075

A182-F321

STANDARD CLASS

NOTE: Not to be used over 1000°F (538°C).

Working Pressure by Classes, psig

CLASS		150	300	600	800	900	1,500	1,690	2,500	2,680	4,500
Shell Test, psig		413	1,080	2,160	2,880	3,240	5,400	6,083	9,000	9,645	16,200
Seat Test, psig		303	792	1,584	2,112	2,376	3,960	4,461	6,600	7,073	11,880
-20 to 100 °F	-29 to 38 °C	275	720	1,440	1,920	2,160	3,600	4,056	6,000	6,430	10,800
200	93.5	250	650	1,295	1,730	1,945	3,240	3,650	5,400	5,785	9,720
300	149.0	230	595	1,190	1,585	1,785	2,975	3,350	4,960	5,315	8,930
400	204.5	200	550	1,105	1,470	1,655	2,760	3,110	4,600	4,930	8,280
500	260.0	170	515	1,030	1,375	1,550	2,580	2,905	4,300	4,605	7,740
600	315.5	140	485	975	1,300	1,460	2,435	2,745	4,060	4,355	7,310
650	343.5	125	475	950	1,265	1,425	2,375	2,675	3,960	4,245	7,130
700	371.0	110	465	930	1,240	1,395	2,330	2,625	3,880	4,160	6,985
750	399.0	95	460	915	1,220	1,375	2,290	2,580	3,820	4,095	6,875
800	426.5	80	450	900	1,205	1,355	2,255	2,540	3,760	4,030	6,770
850	454.5	65	445	895	1,190	1,340	2,230	2,515	3,720	3,990	6,695
900	482.0	50	440	885	1,180	1,325	2,210	2,490	3,680	3,945	6,625
950	510.0	35	385	775	1,030	1,160	1,930	2,175	3,220	3,450	5,795
1000	538.0	20	365	725	970	1,090	1,820	2,045	3,030	3,235	5,450

A182-F347

STANDARD CLASS

NOTE: Not to be used over 1100°F (538°C).

Working Pressure by Classes, psig

CLASS		150	300	600	800	900	1,500	1,690	2,500	2,680	4,500
Shell Test, psig		413	1,080	2,160	2,880	3,240	5,400	6,083	9,000	9,645	16,200
Seat Test, psig		303	792	1,584	2,112	2,376	3,960	4,461	6,600	7,073	11,880
-20 to 100 °F	-29 to 38 °C	275	720	1,440	1,920	2,160	3,600	4,055	6,000	6,430	10,800
200	93.5	255	660	1,325	1,765	1,985	3,310	3,725	5,520	5,915	9,935
300	149.0	230	615	1,235	1,645	1,850	3,085	3,475	5,140	5,505	9,250
400	204.5	200	575	1,150	1,535	1,730	2,880	3,245	4,800	5,145	8,640
500	260.0	170	540	1,085	1,445	1,625	2,710	3,055	4,520	4,845	8,135
600	315.5	140	515	1,030	1,375	1,550	2,580	2,905	4,300	4,605	7,740
650	343.5	125	505	1,015	1,350	1,520	2,530	2,851	4,220	4,525	7,595
700	371.0	110	495	995	1,325	1,490	2,485	2,795	4,140	4,435	7,450
750	399.0	95	490	985	1,310	1,475	2,460	2,770	4,100	4,395	7,380
800	426.5	80	485	975	1,300	1,460	2,435	2,745	4,060	4,355	7,310
850	454.5	65	485	970	1,295	1,455	2,425	2,730	4,040	4,330	7,270
900	482.0	50	450	900	1,200	1,350	2,245	2,530	3,745	4,015	6,740
950	510.0	35	385	775	1,030	1,160	1,930	2,175	3,220	3,450	5,795
1000	538.0	20	365	725	970	1,090	1,820	2,050	3,030	3,250	5,450

GATE VALVES – API 602 / ASME B16.34

No.	ASTM Designation Parts	A105N	A350		A182					A182				
			LF2	LF3	F304/L	F316/L	F321	F347	F51	F5	F9	F11	F22	F91
1	Body	A105N	LF2	LF3	F304/L	F316/L	F321	F347	F51	F5	F9	F11	F22	F91
2	Seat Ring	A276-410+STL		A276-316+STL			A276	A276	UNS	A276-410+STL				
		A105 +STL*	LF2 +STL*	LF3 +STL*	A276-316 +STL*		-321 +STL	-347 +STL	S31803 +STL	F5 +STL*	F9 +STL*	F11 +STL*	F22 +STL*	F91 +STL*
3	Wedge	A217-CA15		A351-CF8M+STL			A276	A276	UNS	A217-CA15				
		A276-410*		A276-316+STL*			-321 +STL	-347 +STL	S31803 +STL	A276-410+STL*				
4	Stem	A276-410		A276-304		A276 -316	A276 -321	A276 -347	UNS S31803	A276-410				
5	Gasket	304 Spiral Wound Graphite				316 SWG	321 SWG	347 SWG	Duplex SWG	304 Spiral Wound Graphite				
6	Bonnet	A105N	LF2	LF3	F304/L	F316/L	F321	F347	F51	F5	F9	F11	F22	F91
7	Bonnet Bolt	A193-B7	A320-L7		A193-B8					A193-B16				
8	Gland Packing	Graphoil												
10	Gland	316 Stainless Steel												
11	Gland Flange	A105		A182-F304					A105					
				A105*										
12	Gland Nut	A194-2H		A194-8					A194-2H					
				A194-2H*										
13	Gland Bolt	A193-B6		A193-B8					A193-B6					
				A193-B7*		A193-B7*								A193-B7*
14	Yoke Sleeve	A582-416												
		High Tension Brass*												
15	Handwheel	A47												
16	Name Plate	Aluminium			304 Stainless Steel					Aluminium				
17	Handwheel Nut	A563-A												
20	Yoke	A105												

STL : Stellite 6 Faced

SWG : Spiral Wound Graphite

A182-F304/L : Dual Certificate Material for A182-F304 & A182-F304L

A182-F316/L : Dual Certificate Material for A182-F316 & A182-F316L

DUPLEX : Duplex Stainless Steel

* ASME CLASS 1500 and Above

· Other materials also available on request

GLOBE VALVES – ASME B16.34 / BS 5352

No.	ASTM Designation Parts	A105N	A350		A182					A182				
			LF2	LF3	F304/L	F316/L	F321	F347	F51	F5	F9	F11	F22	F91
1	Body	A105N	LF2	LF3	F304/L	F316/L	F321	F347	F51	F5	F9	F11	F22	F91
2	Seat	Integral Hardfaced Stellite 6												
3	Disc	A217-CA15	A351-CF8M+STL		A276-321	A276-347	UNS S31803	A217-CA15						
		A276-410+STL*	A276-316+STL*		+STL	+STL	+STL	A276-410+STL*						
4	Stem	A276-410	A276-304	A276-316	A276-321	A276-347	UNS S31803	A276-410						
			A276-316*											
5	Gasket	304 Spiral Wound Graphite			316 SWG	321 SWG	347 SWG	Duplex SWG	304 Spiral Wound Graphite					
6	Bonnet	A105N	LF2	LF3	F304/L	F316/L	F321	F347	F51	F5	F9	F11	F22	F91
7	Bonnet Bolt	A193-B7	A320-L7		A193-B8					A193-B16				
8	Gland Packing	Graphoil												
9	Packing Ring	A276-316												
10	Gland	316 Stainless Steel												
11	Gland Flange	A105	A182-F304					A105						
			A105*											
12	Gland Nut	A194-2H	A194-8					A194-2H						
			A194-2H*											
13	Gland Bolt	A193-B6	A193-B8					A193-B6						
		A193-B7*	A193-B7*					A193-B7*						
14	Yoke Sleeve	A582-416												
		High Tension Brass*												
15	Handwheel	A47												
16	Name Plate	Aluminium		304 Stainless Steel					Aluminium					
17	Handwheel Nut	A194-2H												
20	Yoke	A105												
39	Disc Pad	316 Stainless Steel												

STL : Stellite 6 Faced

SWG : Spiral Wound Graphite

A182-F304/L : Dual Certificate Material for A182-F304 & A182-F304L

A182-F316/L : Dual Certificate Material for A182-F316 & A182-F316L

DUPLEX : Duplex Stainless Steel

* ASME CLASS 1500 and Above

· Other materials also available on request

PISTON CHECK VALVES – ASME B16.34 / BS 5352

No.	ASTM Designation Parts	A105N	A350		A182					A182				
			LF2	LF3	F304/L	F316/L	F321	F347	F51	F5	F9	F11	F22	F91
1	Body	A105N	LF2	LF3	F304/L	F316/L	F321	F347	F51	F5	F9	F11	F22	F91
2	Seat	Integral Hardfaced Stellite 6												
3	Disc	A276-410	A276-316+STL		A276-321	A276-347	UNS S31803	A276-410						
					+STL	+STL	+STL							
4	Spring	A276-316			Inconel X-750					A276-316				
5	Gasket	304 Spiral Wound Graphite			316 SWG	321 SWG	347 SWG	Duplex SWG	304 Spiral Wound Graphite					
6	Cover	A105N	LF2	LF3	F304/L	F316/L	F321	F347	F51	F5	F9	F11	F22	F91
7	Cover Bolt	A193-B7	A320-L7		A193-B8					A193-B16				
16	Name Plate	Aluminium		304 Stainless Steel					Aluminium					

SWING CHECK VALVES – ASME B16.34 / BS 5352

No.	ASTM Designation Parts	A105N	A350		A182					A182				
			LF2	LF3	F304/L	F316/L	F321	F347	F51	F5	F9	F11	F22	F91
1	Body	A105N	LF2	LF3	F304/L	F316/L	F321	F347	F51	F5	F9	F11	F22	F91
2	Seat Ring	A276-410	A276-316+STL		A276-321	A276-347	UNS S31803	A276-410+STL						
					+STL	+STL	+STL							
3	Disc	A276-316+STL			A276-321	A276-347	UNS S31803	A276-316+STL						
					+STL	+STL	+STL							
4	Hinge	A351-CF8M												
5	Gasket	304 Spiral Wound Graphite			316 SWG	321 SWG	347 SWG	SWG	304 Spiral Wound Graphite					
6	Cover	A105N	LF2	LF3	F304/L	F316/L	F321	F347	F51	F5	F9	F11	F22	F91
7	Cover Bolt	A193-B7	A320-L7		A193-B8					A193-B16				
8	Retaining Washer	316 Stainless Steel												
9	Support Pin	316 Stainless Steel												
10	Support	316 Stainless Steel												
16	Name Plate	Aluminium		304 Stainless Steel					Aluminium					

STL : Stellite 6 Faced

SWG : Spiral Wound Graphite

A182-F304/L : Dual Certificate Material for A182-F304 & A182-F304L

A182-F316/L : Dual Certificate Material for A182-F316 & A182-F316L

DUPLEX : Duplex Stainless Steel

* ASME CLASS 1500 and Above

· Other materials also available on request

Valve Type	Class	Port	1/2	3/4	1	1-1/4	1-1/2	2
Gate	150~800	Reduced	7	14	29	84	93	155
	1500	Reduced	13	15	29	81	100	148
	150~800	Full	17	33	57	154	154	288
	1500	Full	15	28	45	122	122	220
	2500	Full	14	27	48	113	116	172
Globe	150~800	Reduced	2	3	4	8	15	30
	1500	Reduced	2	3	5	10	18	28
	150~800	Full	3	5	9	15	21	38
	1500	Full	3	4	7	12	18	28
	2500	Full	1	2	4	9	12	22
	4500	Full	1	2	3	8	8	11
Lift Check	150~800	Reduced	1.5	2	4	6	13	24
	1500	Reduced	1.4	2	4	8	19	23
	150~800	Full	2	4	7	11	16	28
	1500	Full	2	3	5	9	13	21
	2500	Full	1	2	3	7	9	17
	4500	Full	1	2	3	6	7	8
Swing Check	150~800	Reduced	8	10	22	50	66	84
	1500	Reduced	8	9	19	40	52	80
	800	Full	10	25	48	70	92	115
Y Pattern Globe	150~800	Reduced	3	6	11	19	34	48
	1500/1690	Reduced	3	5	10	15	29	41
	800	Full	6	12	21	35	51	90
	1500/1690	Full	5	10	16	30	43	66
	2500/2680	Full	4	7	10	22	25	53
	4500	Full	2	5	8	19	20	35
Y Pattern Lift Check	150~800	Reduced	3	6	11	19	34	48
	1500/1690	Reduced	3	5	10	15	29	41
	800	Full	6	9	15	28	41	78
	1500/1690	Full	4	8	12	24	35	58
	2500/2680	Full	3	4	8	18	23	46
	4500	Full	2	3	6	16	16	21

CODE TABLE

SAMPLE VALVE

1 2 3 4 5 6 7 8

AA F 24 AN A B 1 C

GATE, CLASS 800, 316/L BODY, 316FHF TRIM, SOCKET WELD ENDS, WELDED BONNET RED.PORT, GRAPHOIL PACKING

1 VALVE TYPE		2 CLASS	3 SHELL MATERIAL		4 TRIM MATERIAL						
AA	GATE	A	125	11	A105N, WCB	32	F91, C12A				
AB	GLOBE	B	150	13	LF2, LC2	33	MONEL	AB	CR13	CR13	STELLITE 6
AC	PISTON CHECK	C	200	14	LF3, LC3	34		AC	CR13	CR13+ST 6	STELLITE 6
AD	SWING CHECK	D	300	15	F5, C5	35	ALLOY 625 NO6625	AD	304	304/CF8	STELLITE 6
AE	BALL CHECK	E	600	16	F9, C12	36	ALLOY 825 NO8825	AG	304	304/CF8+ST 6	STELLITE 6
AF	NEEDLE GLOBE	F	800	17	F11, WC6	37	ALLOY 800 NO8800	AL	316	316/CF8M	316/CF8M
AG	ANGLE GLOBE	G	900	18	F22, WC9	38	ALLOY 800H NO8810	AM	316	316/CF8M	STELLITE 6
AH	GLOBE STOP CHECK	H	1500	21	F304L, CF3	39	ALLOY-20	AN	316	316/CF8M+ST 6	STELLITE 6
AJ	PISTON CHECK (SPRING LOADED)	J	2500	22	F304H	41	TITANIUM	AO	316L	316L+ST 6	STELLITE 6
AK	BALL CHECK (SPRING LOADED)	K	4500	24	F316/F316L	42	F317, CG8M	AQ	317	317+ST 6	STELLITE 6
AL	BOILER BLOWDOWN	L	1690	25	F316H	43	F317L, CG3M	AR	317L	317L+ST 6	STELLITE 6
BA	GATE (321 STAINLESS BELLOWS)	M	2680	26	F321	48	F304/F304L	AT	321	321+ST 6	STELLITE 6
BB	GLOBE (321 STAINLESS BELLOWS)	Z	SPECIAL	27	F321H	50	LCC	AU	347	347+ST 6	STELLITE 6
BG	GATE (INCONEL 625 BELLOWS)			28	F347, CF8C	51	F347H	AW	DUPLEX	DUPLEX+ST 6	STELLITE 6
BH	GLOBE (INCONEL 625 BELLOWS)			29	F51			BC	MONEL	MONEL+ST 6	MONEL
BI	Y GLOBE (321 STAINLESS BELLOWS)			31	F53			BD	MONEL	MONEL	STELLITE 6
BJ	Y GLOBE (INCONEL 625 BELLOWS)							BE	INCOLOY	INCOLOY	INCOLOY
CG	ANGLE GLOBE STOP CHECK					99	SPECIAL	BH	HASTELLOY-B	HASTELLOY-B	HASTELLOY-B
DB	Y GLOBE							BJ	HASTELLOY-C	HASTELLOY-C	HASTELLOY-C
DC	Y PISTON CHECK (SPRING LOADED)							BK	ALLOY 20	ALLOY 20	ALLOY 20
DD	Y NEEDLE GLOBE							BL	TITANIUM	TITANIUM	TITANIUM
DE	Y BALL CHECK (SPRING LOADED)							CA	ALLOY 825	ALLOY 825+ST 6	STELLITE 6
DF	Y GLOBE STOP CHECK							CB	ALLOY 825	ALLOY 825	ALLOY 825
ZZ	SPECIAL							SB	CR13 (1)	CR13	STELLITE 6
								SC	CR13 (1)	CR13+ST 6	STELLITE 6
								SN	316 (1)	316+ST 6	STELLITE 6
								SY	MONEL (1)	MONEL	MONEL
								SZ	MONEL (1)	MONEL	STELLITE 6
								ZZ	SPECIAL	SPECIAL	SPECIAL

(1) NACE MR01-75 SERVICE

5 END CONNECTION		6 BONNET STYLE		7 BORE TYPE		8 GASKET AND PACKING		
A	SOCKET WELD (ASME)	A	BOLTED BONNET	1	REDUCED	A	304 SPIRAL WOUND+GRAPHITE	GRAPHOIL
B	BW (SPECIFY BORE)	B	WELDED BONNET	2	FULL	B	304L SPIRAL WOUND+GRAPHITE	GRAPHOIL
C	NIPPLE STUB ENDS	C	SEAL WELDED BONNET	9	SPECIAL	C	316 SPIRAL WOUND+GRAPHITE	GRAPHOIL
G	EXTENDED BODY MSW x FNPT	D	PRESSURE SEAL BONNET			D	316L SPIRAL WOUND+GRAPHITE	GRAPHOIL
H	EXTENDED BODY MSW x FSW	E	RING JOINT BONNET			E	MONEL SPIRAL WOUND+GRAPHITE	GRAPHOIL
J	SW x NIPPLE (STUB END)	F				F	A20 SPIRAL WOUND+GRAPHITE	GRAPHOIL
K	NPT x NIPPLE (STUB END)	G	COMPACT BOLTED BONNET BELLOWSEAL (GLOBE ONLY)			G	304 SPIRAL WOUND+TEFLON	TEFLON
L	EXTENDED BODY MNPT x FNPT	H	BONNETLESS			H	304L SPIRAL WOUND+TEFLON	TEFLON
M	EXTENDED BODY MNPT x FSW	J	EXTENDED BOLTED BONNET			J	316 SPIRAL WOUND+TEFLON	TEFLON
N	FNPT THREADED BOTH ENDS	K	EXTENDED WELDED BONNET			K	316L SPIRAL WOUND+TEFLON	TEFLON
P	PT	L	CRYOGENIC BOLTED BONNET			L	MONEL SPIRAL WOUND+TEFLON	TEFLON
Q	FLAT FACE	M	CRYOGENIC WELDED BONNET			M	A20 SPIRAL WOUND+TEFLON	TEFLON
R	RAISED FACE					N	304 SPIRAL WOUND+TEFLON	BRAIDED TFE
S	SOCKET WELD x FNPT					P	304L SPIRAL WOUND+TEFLON	BRAIDED TFE
T	RING TYPE JOINT FACE					Q	316 SPIRAL WOUND+TEFLON	BRAIDED TFE
V	SW (JIS)					R	316L SPIRAL WOUND+TEFLON	BRAIDED TFE
X	SW (JIS) x PT					S	MONEL SPIRAL WOUND+TEFLON	BRAIDED TFE
2	EXTENDED BODY BW x FNPT	Z	SPECIAL			T	A20 SPIRAL WOUND+TEFLON	BRAIDED TFE
3	EXTENDED BODY BW x FSW					Z	SPECIAL	SPECIAL
4	EXTENDED BODY IREB x FNPT							
5	EXTENDED BODY IREB x FSW							
Z	SPECIAL							